



What's new in Spring for Apache Kafka 4?



We serve around
41 million
customers

In more than
100
countries

> 60.000
employees

 Located over
35 locations

~21.000
working in tech

ING



We serve around
41 million
customers

In more than
100
countries

> **60.000**
employees

 Located over
35 locations

~21.000
working in tech

ING



10+ year
in production



1.500
Development teams



2.500.000
Events a second



+



Spring for Apache Kafka



What are we going to cover today?

- Practical migration path to **Spring Kafka 4**
- KIP-932: **Kafka Queues** with shared consumers enabling concurrent message processing from the same partition.
- KIP-848: The **new consumer rebalance protocol** for faster and more efficient rebalances in your Spring Kafka applications.
- **Wrap-up**

What are we going to cover today?

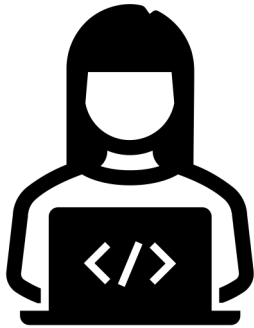

Apply in your
own projects



Spring
Kafka
in action



Understand
tradeoffs

What's a KIP?

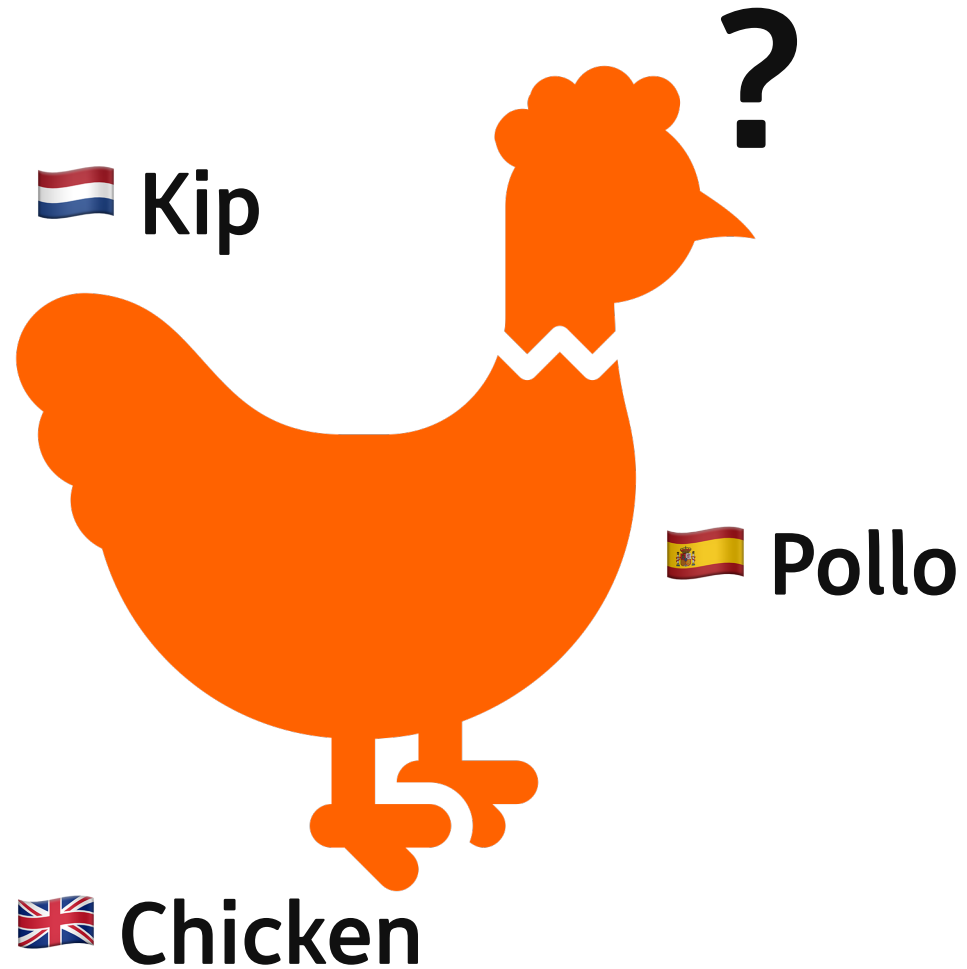

Kafka Improvement Proposals

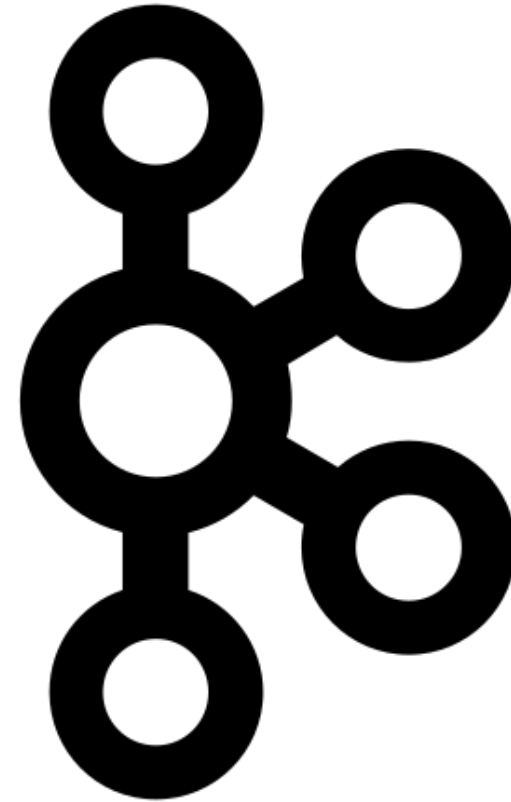

Spring for Apache Kafka

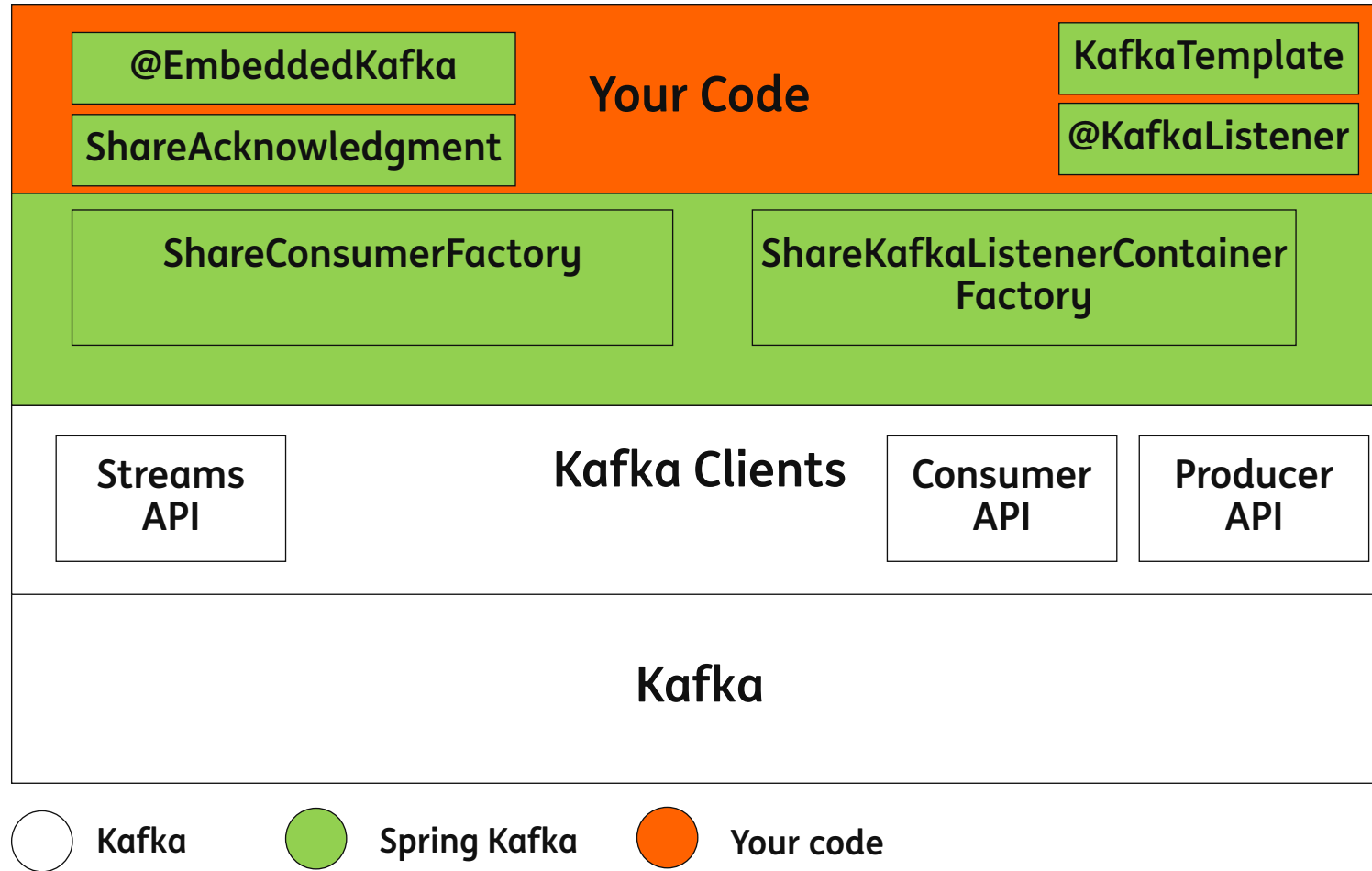

Practical migration path to Spring Kafka 4



Upgrade to Spring Boot 4 / Spring Kafka 4

Spring Boot 3.5.x

```
<dependency>  
  <groupId>org.springframework.kafka</groupId>  
  <artifactId>spring-kafka</artifactId>  
</dependency>
```

```
<dependency>  
  <groupId>org.springframework.kafka</groupId>  
  <artifactId>spring-kafka-test</artifactId>  
  <scope>test</scope>  
</dependency>
```

```
<dependency>  
  <groupId>org.apache.kafka</groupId>  
  <artifactId>kafka-clients</artifactId>  
  <version>3.9.x</version>  
</dependency>
```



Spring Boot 4.0.x (latest release)

```
<dependency>  
  <groupId>org.springframework.boot</groupId>  
  <artifactId>spring-boot-starter-kafka</artifactId>  
</dependency>
```

```
<dependency>  
  <groupId>org.springframework.boot</groupId>  
  <artifactId>spring-boot-starter-kafka-test</artifactId>  
  <scope>test</scope>  
</dependency>
```

```
<dependency>  
  <groupId>org.apache.kafka</groupId>  
  <artifactId>kafka-clients</artifactId>  
  <version>4.1.x</version>  
</dependency>
```



Upgrade to Spring Boot 4 / Spring Kafka 4



Spring Boot 3.5.x

```
<dependency>  
  <groupId>org.springframework.kafka</groupId>  
  <artifactId>spring-kafka</artifactId>  
</dependency>
```

```
<dependency>  
  <groupId>org.springframework.kafka</groupId>  
  <artifactId>spring-kafka-test</artifactId>  
  <scope>test</scope>  
</dependency>
```

```
<dependency>  
  <groupId>org.apache.kafka</groupId>  
  <artifactId>kafka-clients</artifactId>  
  <version>3.9.x</version>  
</dependency>
```



Spring Boot 4.1.x (next release May 2026)

```
<dependency>  
  <groupId>org.springframework.boot</groupId>  
  <artifactId>spring-boot-starter-kafka</artifactId>  
</dependency>
```

```
<dependency>  
  <groupId>org.springframework.boot</groupId>  
  <artifactId>spring-boot-starter-kafka-test</artifactId>  
  <scope>test</scope>  
</dependency>
```

```
<dependency>  
  <groupId>org.apache.kafka</groupId>  
  <artifactId>kafka-clients</artifactId>  
  <version>4.2.x</version>  
</dependency>
```



**Practical migration
path to
Spring Kafka 4
In action**



Upgrade to Spring Boot 4 and Spring Kafka 4

Breaking changes

- To leverage the new features, you need a Kafka 4 cluster
- Requires new baseline for client protocol API: 2.1.0
- Minimum Java Kafka clients version 2.1.0

	Spring Boot	Spring Kafka	Kafka clients	Release date
✓	2.2.x.RELEASE	2.3.x	2.3.x	Oct 2019
✗	2.1.x.RELEASE	2.2.x	2.0.x	Oct 2018

KIP-932

**Queues for Kafka
(Share Consumers)**

Queues for Kafka (Share Consumers)

- GA in: Kafka 4.2 (Spring Boot & Spring Kafka 4.1)
- Share groups vs Consumer Groups
- How does it work?
- Use share consumers in Spring Kafka
 - Important configurations
 - Acknowledgment (Implicit / Explicit)
 - Scaling
- Demo
- Limitations & Trade-offs

Queues for Kafka – How does it work?

Partitions:

- < Kafka 4: Fundamental unit of parallelism in Kafka
- **Data:** distributed across multiple brokers in the Kafka cluster
- **Consumers:** enabling concurrent processing (using consumer groups)

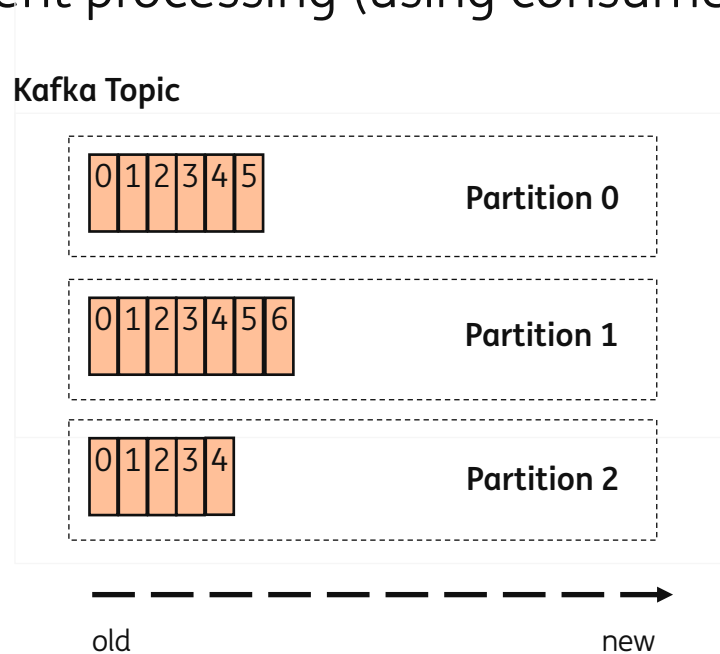

Queues for Kafka – How does it work?

Consumer groups - Partition assignment:

- A consumer can read from multiple partitions
- Each partition is consumed by only one consumer within a group

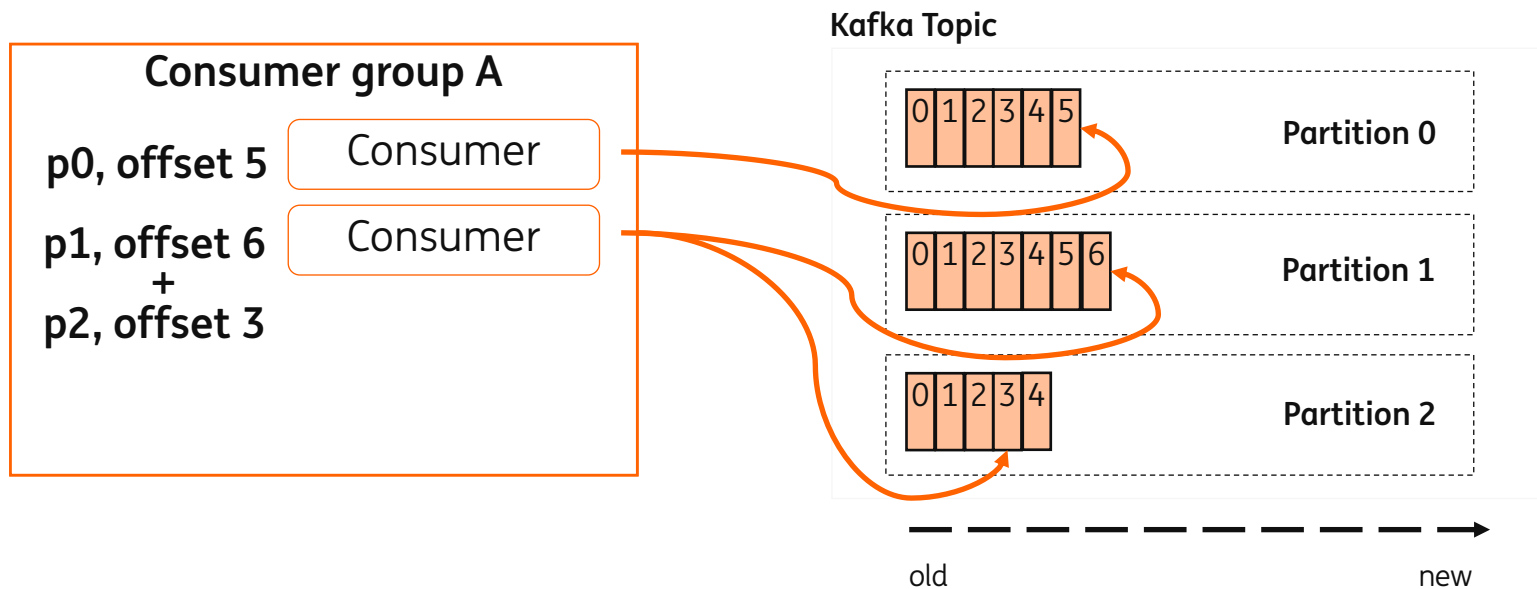

Queues for Kafka – How does it work?

Consumer groups – Load balancing & fault-tolerance:

- Kafka automatically balances partitions among consumers in a group when:
 - A new consumer joins the group
 - An existing consumer leaves the group (or fails)

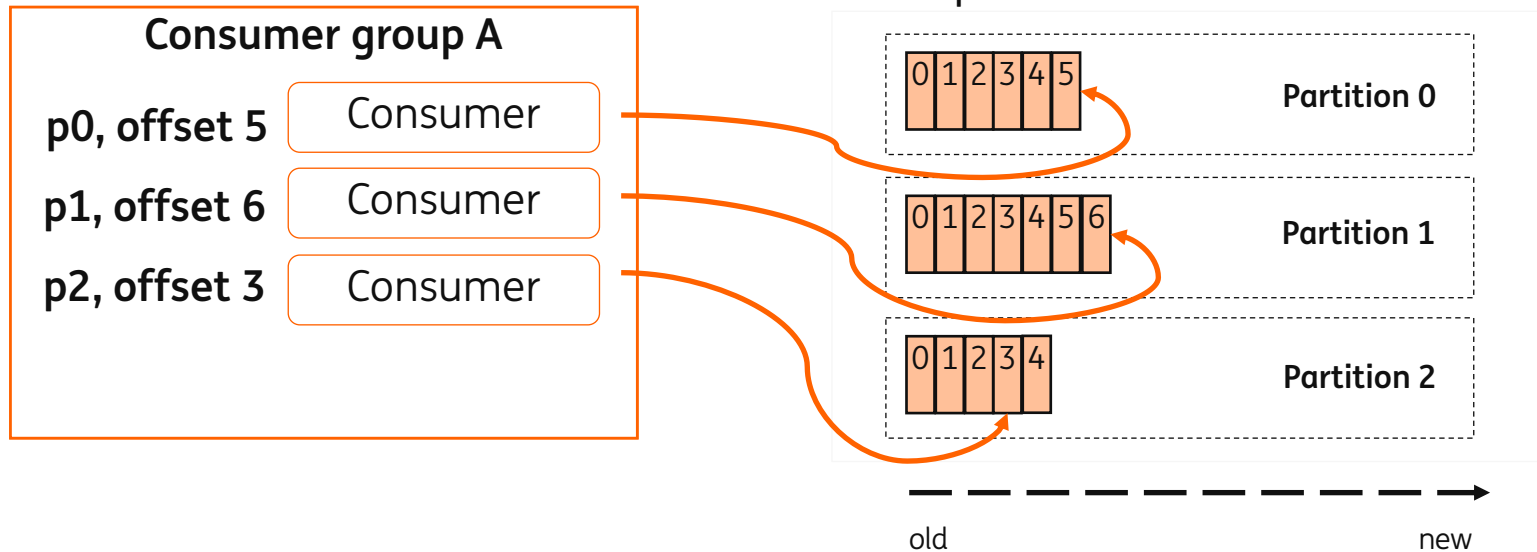

Queues for Kafka – How does it work?

Consumer group Scalability:

- max active consumers in a group == number of partitions
- extra consumers are idle

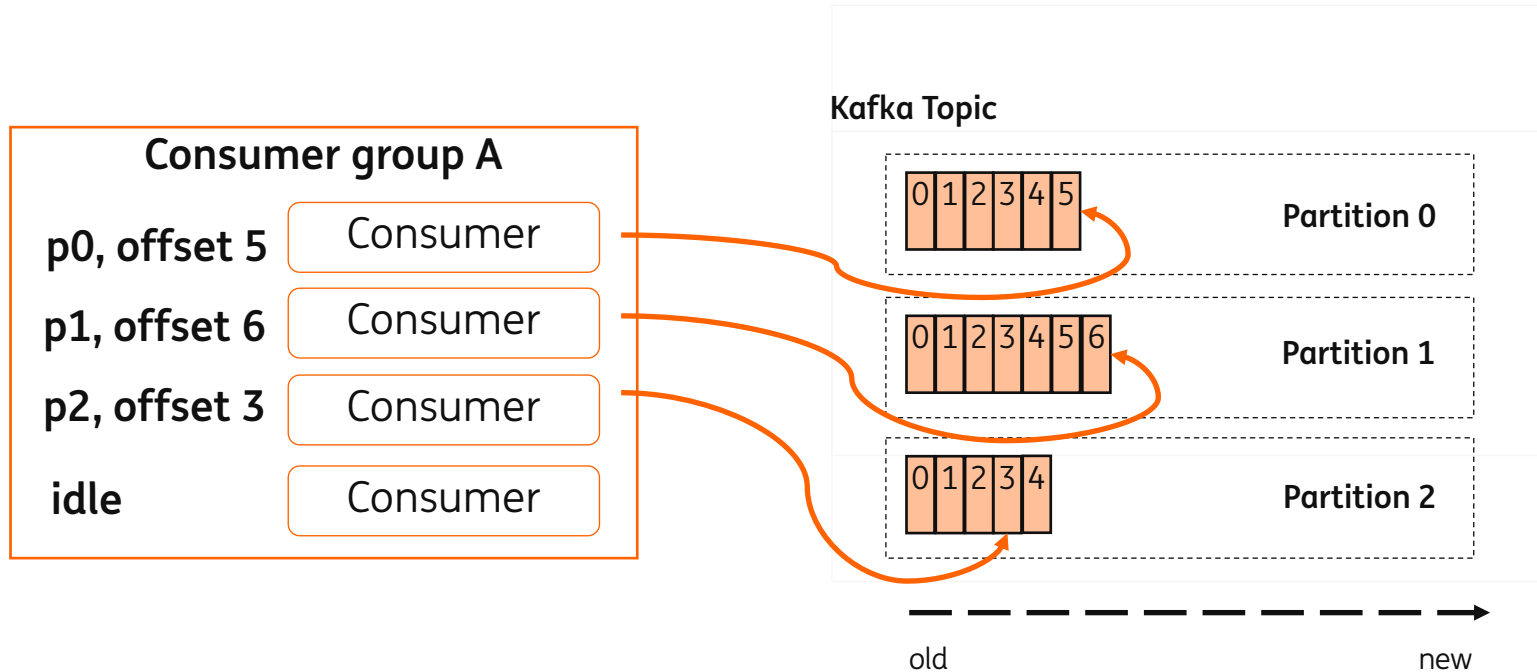

Queues for Kafka – How does it work?

Consumer group limitations:

- No dynamic scaling of consumer
 - Over commit partitions (to handle peak loads)
 - Can't scale down partitions

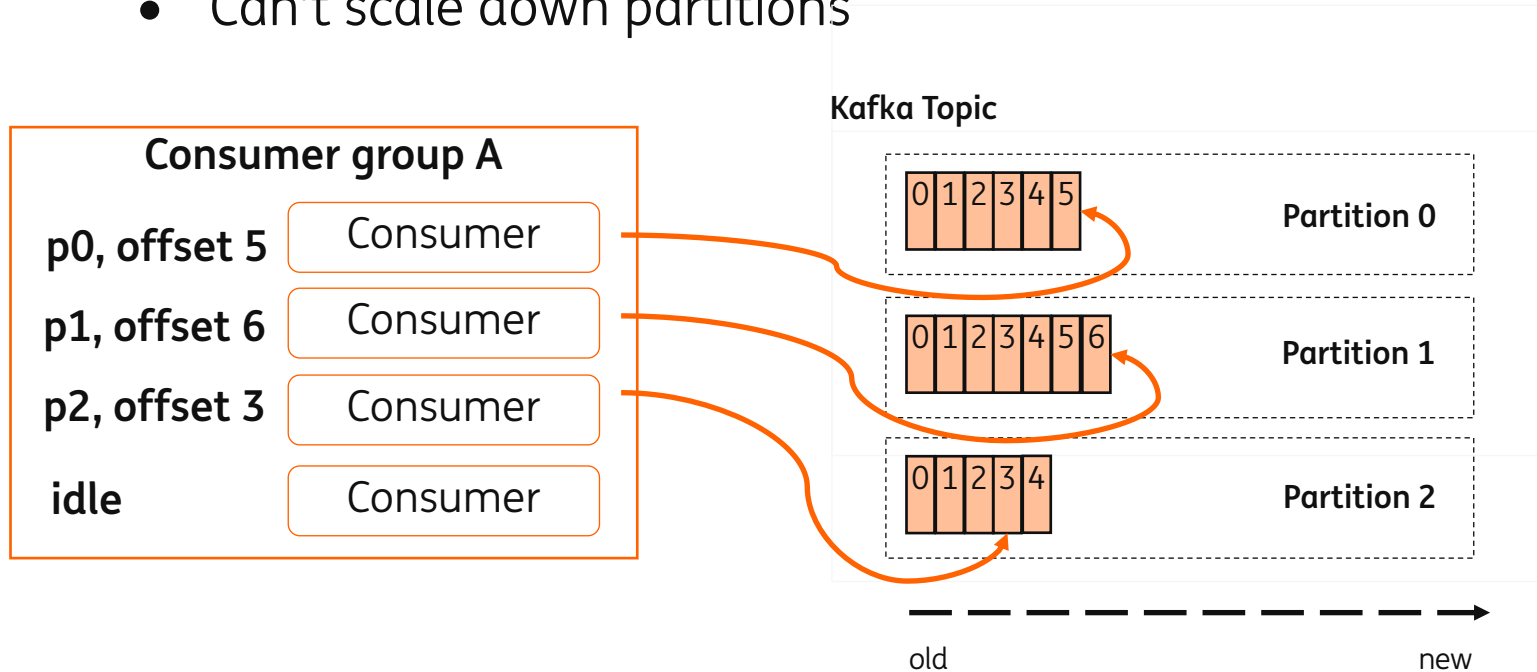

Queues for Kafka – How does it work?

Share group:

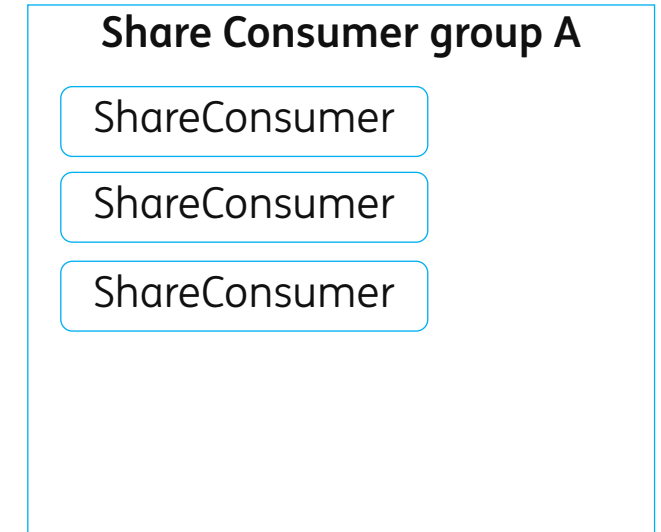
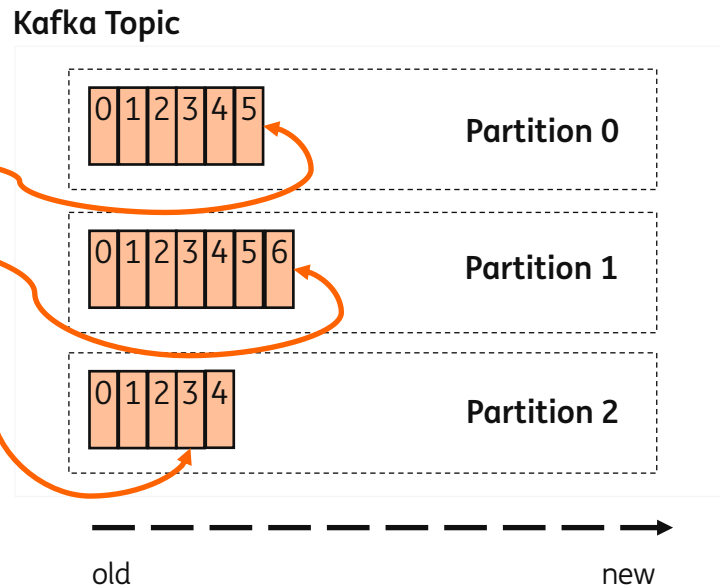
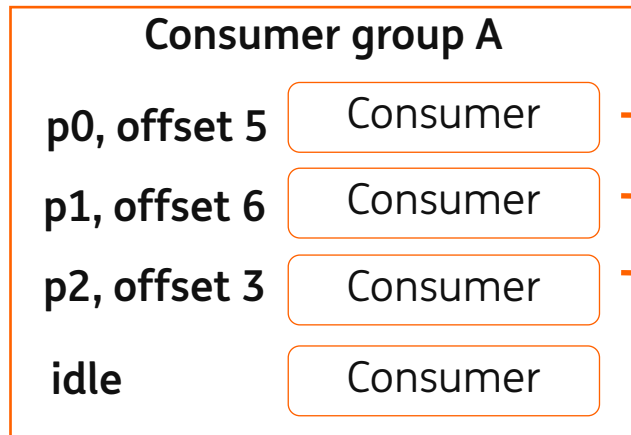

Queues for Kafka – How does it work?

Share group:

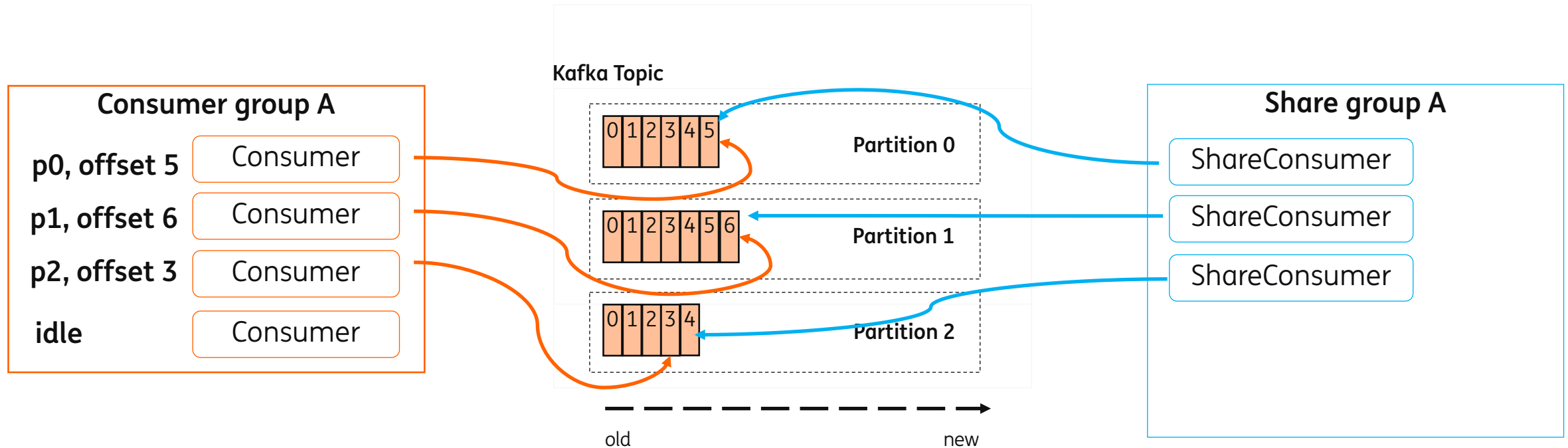

Queues for Kafka – How does it work?

Share group:

- Many consumers per partition (in parallel)

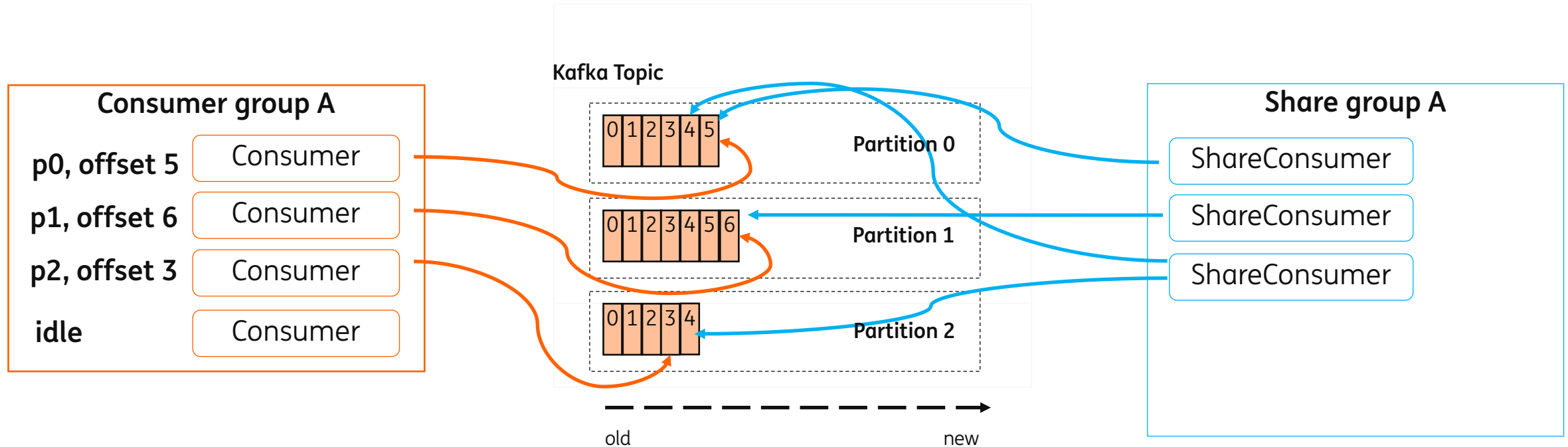

Queues for Kafka – How does it work?

Share group:

- Many consumers per partition (in parallel)
- No idle consumers

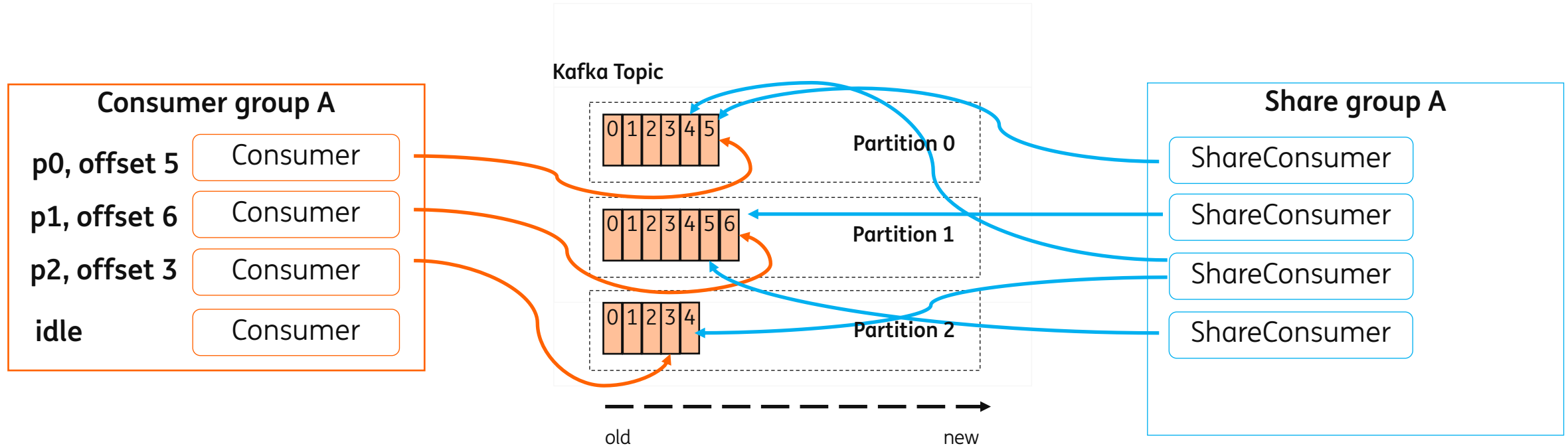

Queues for Kafka – How does it work?

Share group:

- Queue semantics (each record acknowledge and has a state)

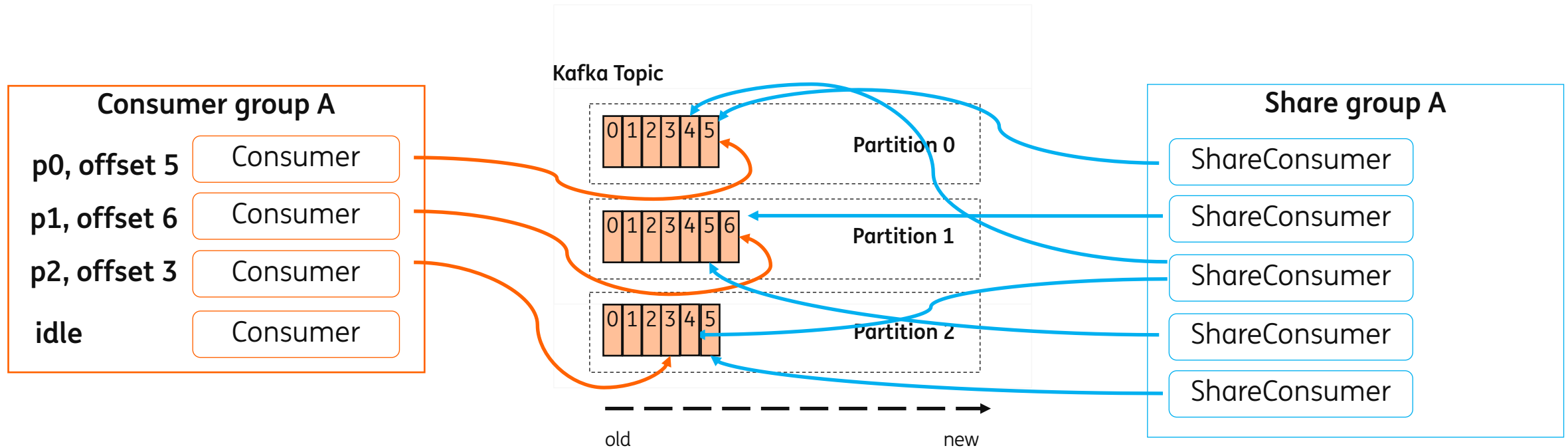

Queues for Kafka – How does it work?

Share group:

- Queue semantics (each record acknowledge and has a state)
- No head of line blocking

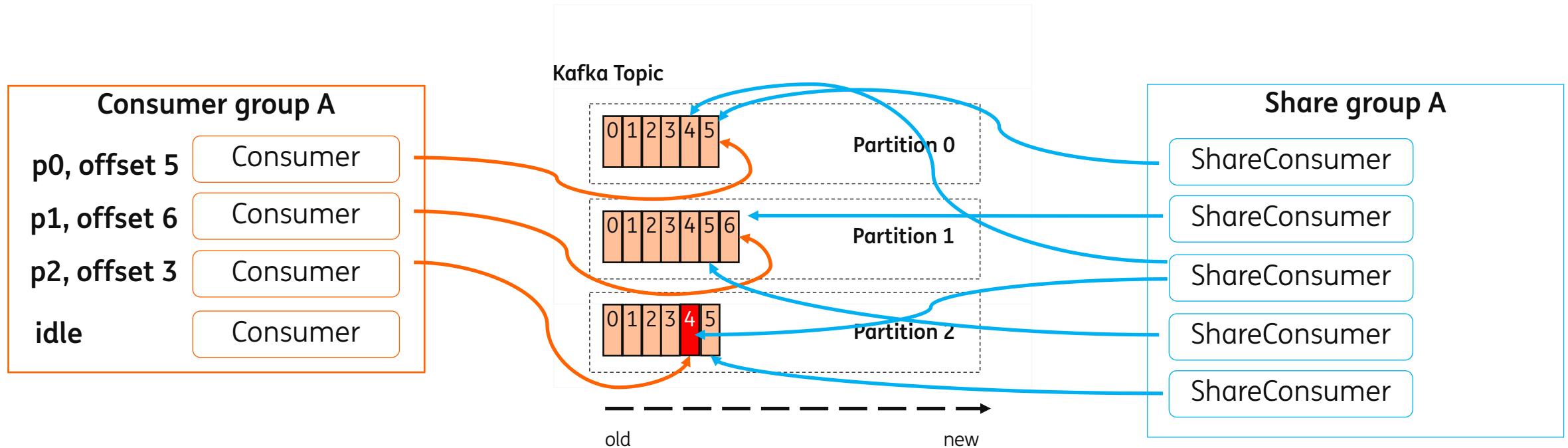

Queues for Kafka – How does it work?

Share group:

- Consumers act as a processing pool
- Like workers in a queue system

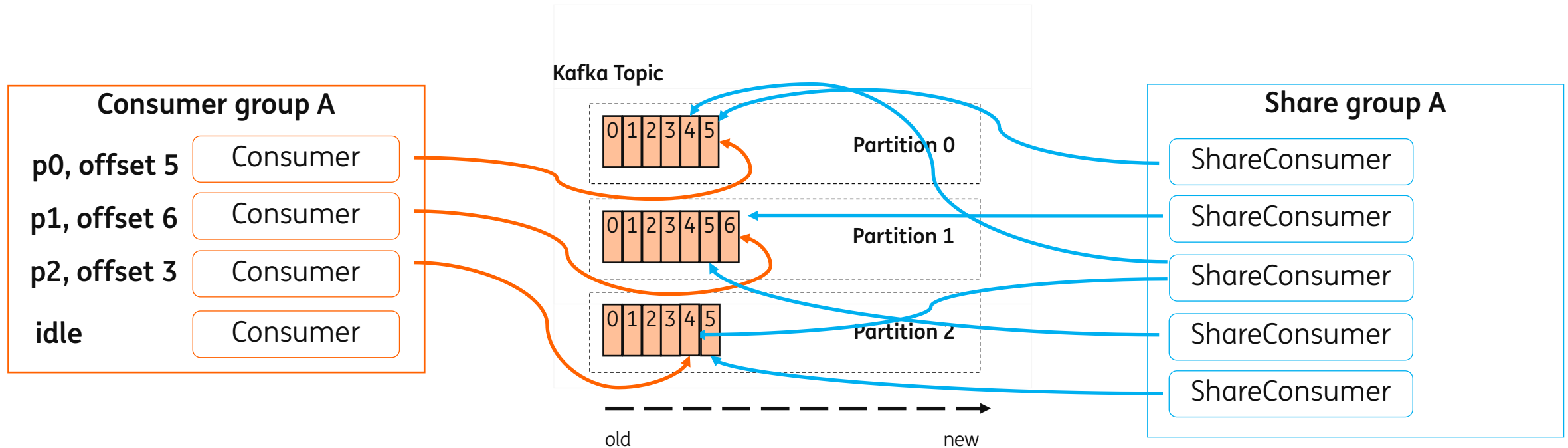

Queues for Kafka – How does it work?

Consumer group limitations:

- No dynamic scaling of consumer
 - Over commit partitions (to handle peak loads)
 - Can't scale down partitions

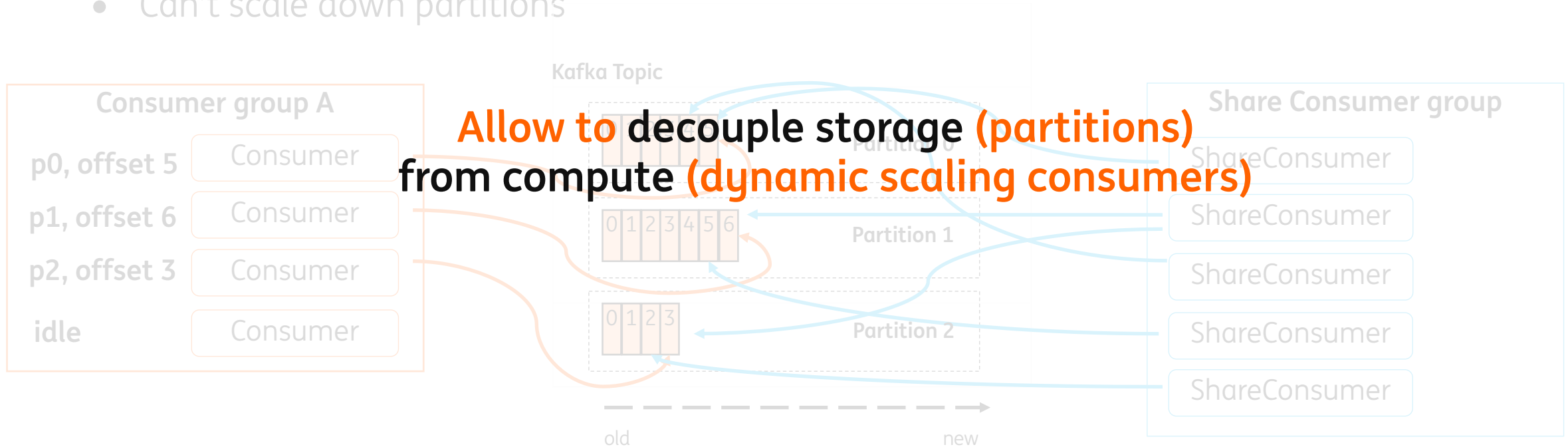

Queues for Kafka – How does it work?

Consumer group limitations:

- No queue semantics
 - No way to ack an individual message
 - Head of Line blocking

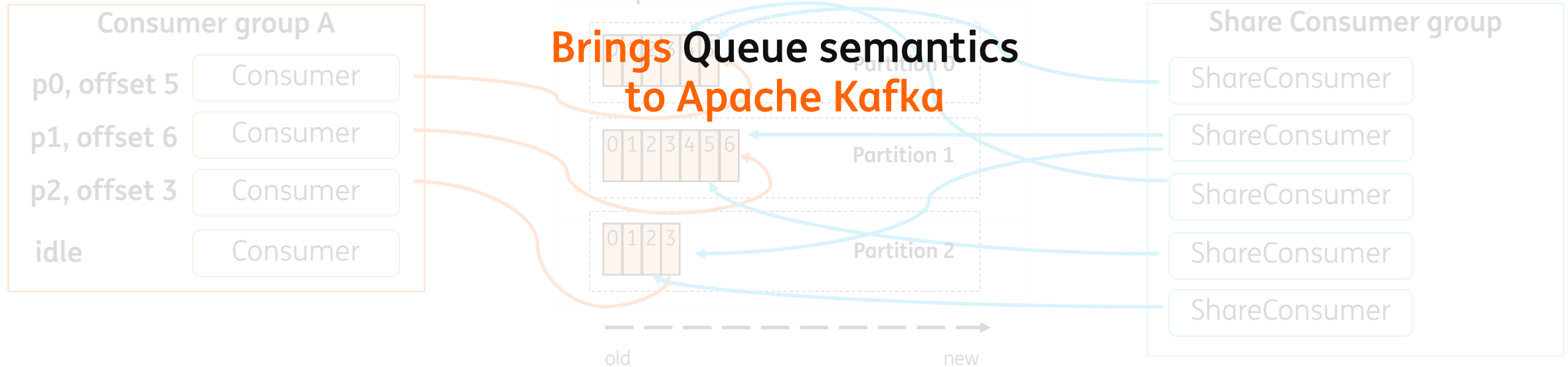

Queues for Kafka – How does it work?

offset:

0	1	2	3	4	5	6	7	8	9	10	11	12	13	14	15

Share group partition

Queues for Kafka – How does it work?

Av = Available
Aq = Acquired
Ack = Acknowledge
Ar = Archived

offset:	0	1	2	3	4	5	6	7	8	9	10	11	12	13	14	15
state:	Av	Av	Av	Av	Av	Av	Av	Av	Av	Av	Av	Av	Av	Av	Av	Av

Share group partition

Queues for Kafka – How does it work?

Av = Available
Aq = Acquired
Ack = Acknowledge
Ar = Archived

offset:	0	1	2	3	4	5	6	7	8	9	10	11	12	13	14	15
state:	Av	Av	Av	Av	Av	Av	Av	Av	Av	Av	Av	Av	Av	Av	Av	Av
delivery count:	0	0	0	0	0	0	0	0	0	0	0	0	0	0	0	0

Share group partition

Queues for Kafka – How does it work?

State machine



Available for
delivery



Being
delivered

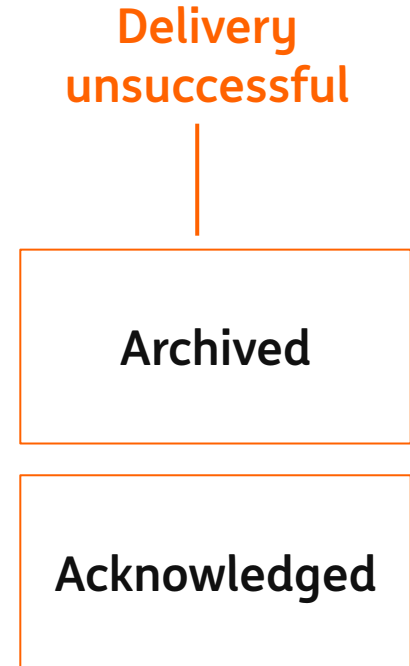

Delivery
unsuccessful

Delivery
successful

Queues for Kafka – How does it work?

Max delivery attempts:

- Broker setting
- Default: 5
- Preventing an infinite retry loop

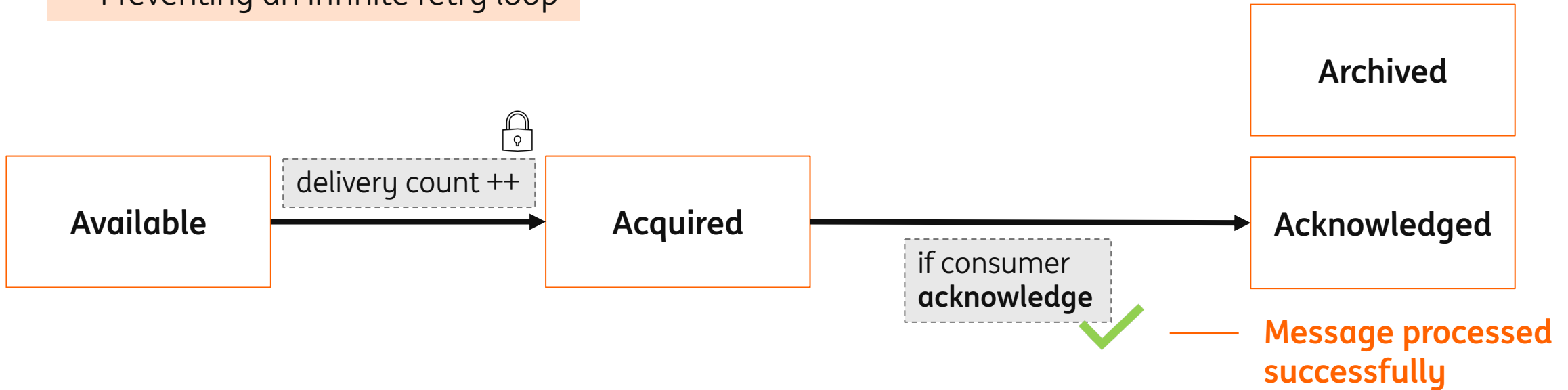

Message state:

- maintained per share group
- message accepted by one group, rejected by another group

Queues for Kafka – How does it work?

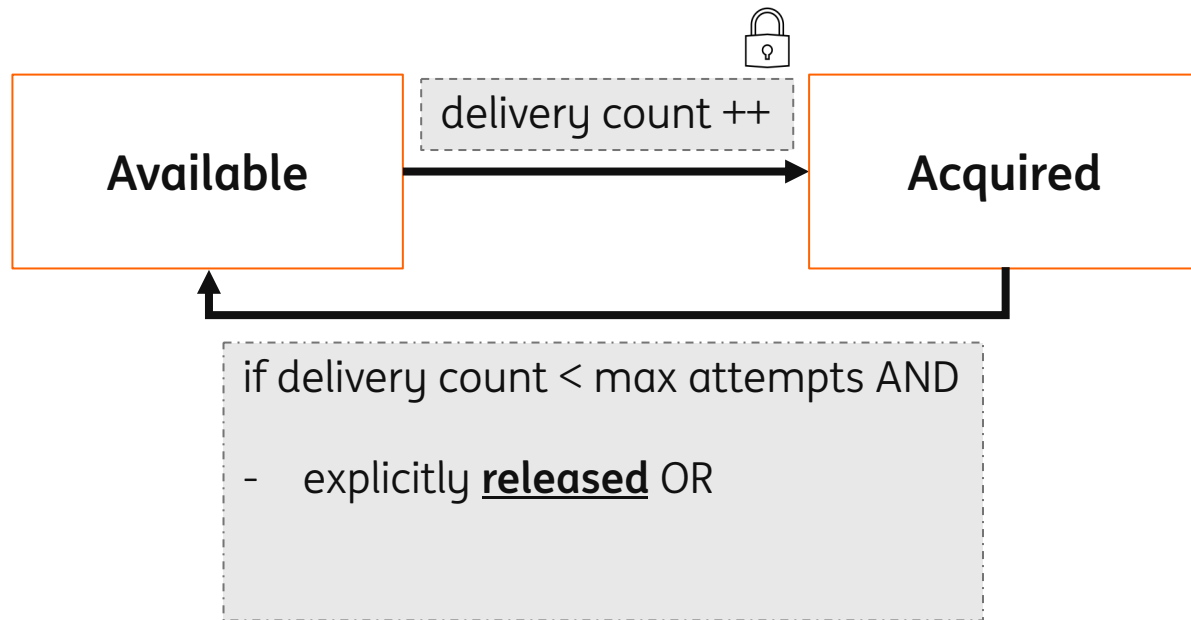

Queues for Kafka – How does it work?

Property:

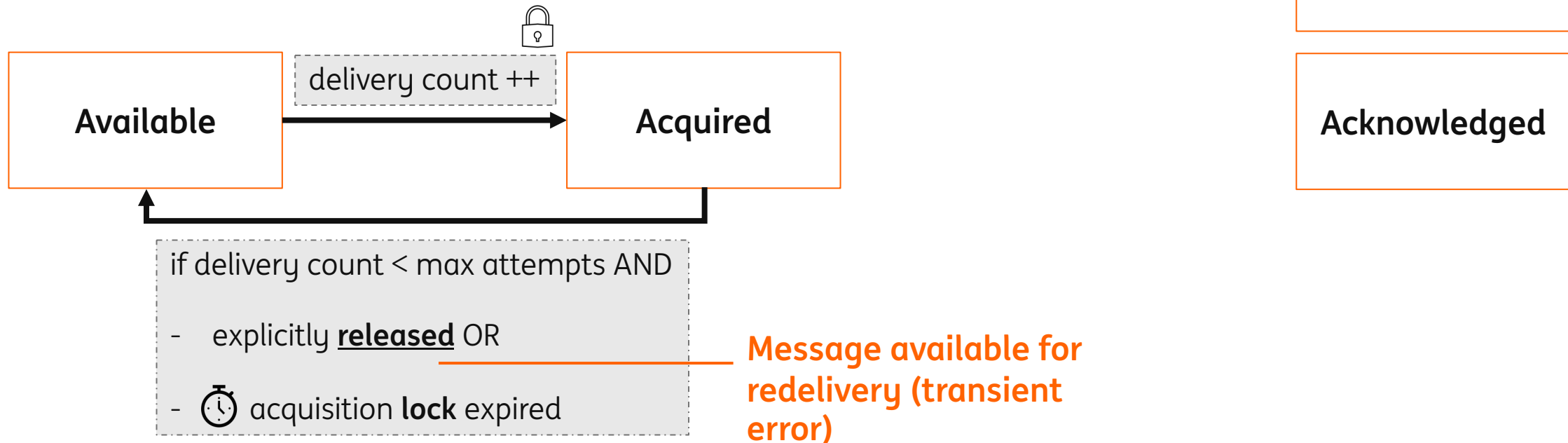

Queues for Kafka – How does it work?

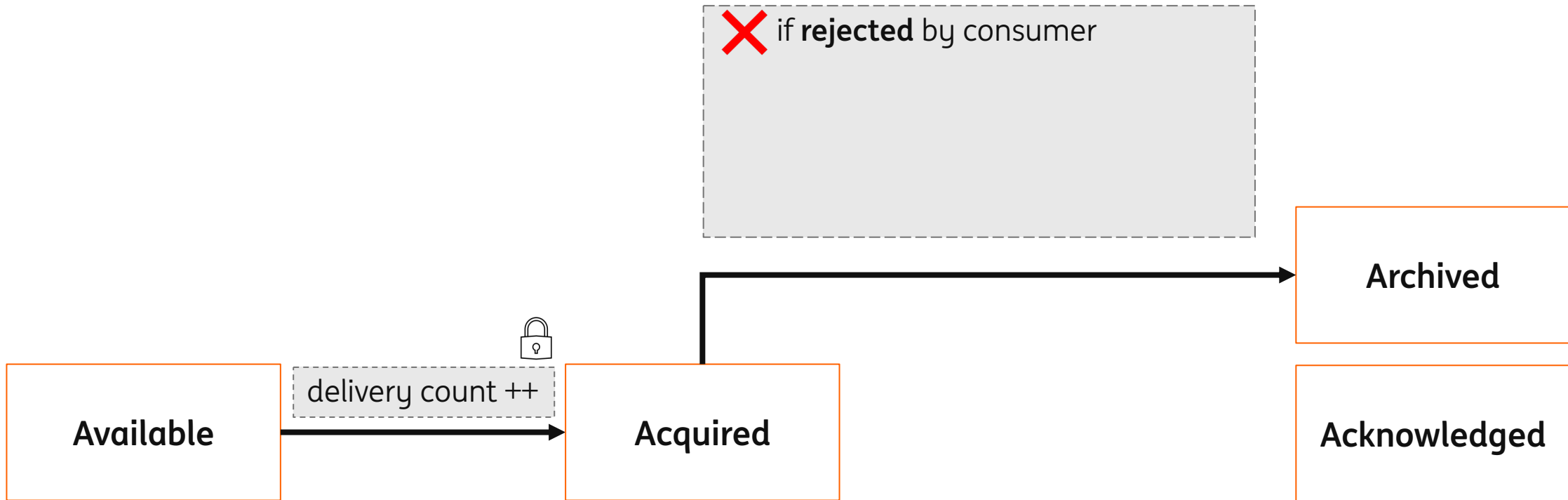

Queues for Kafka – How does it work?

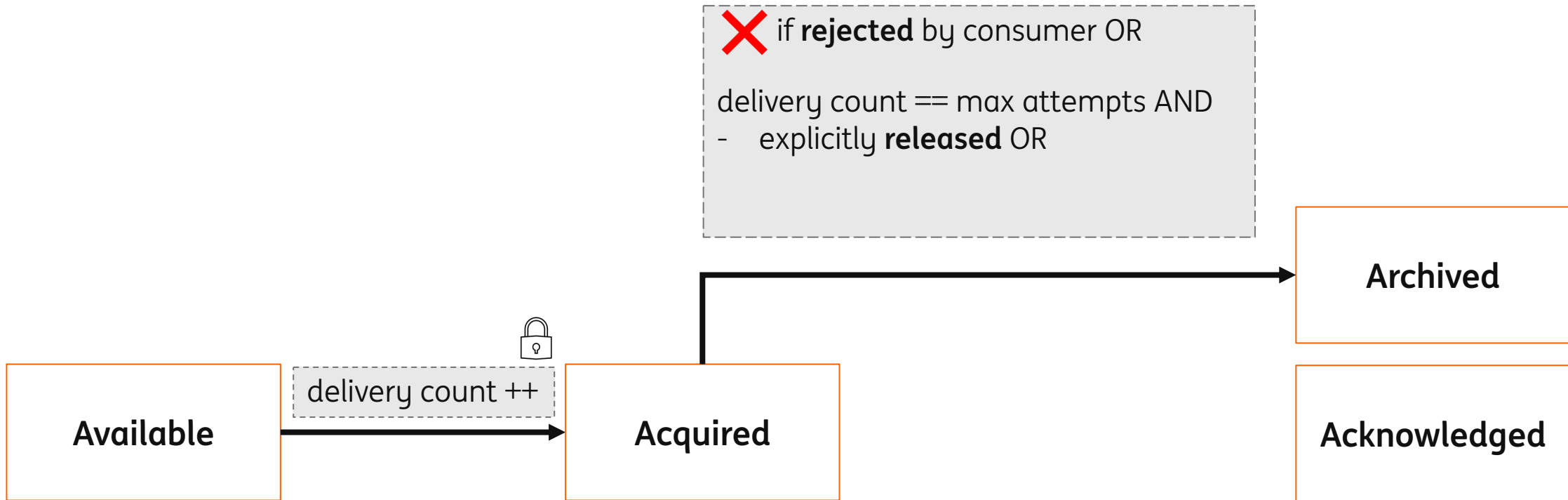

Queues for Kafka – How does it work?

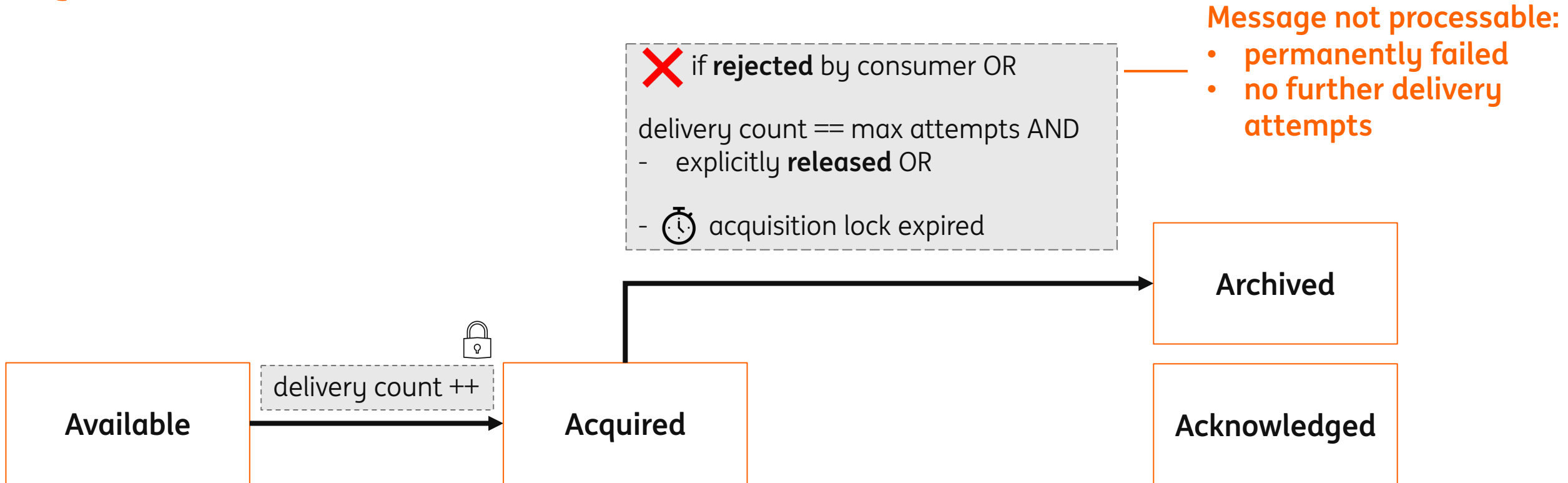

Queues for Kafka – How does it work?

Av = Available
Aq = Acquired
Ack = Acknowledge
Ar = Archived

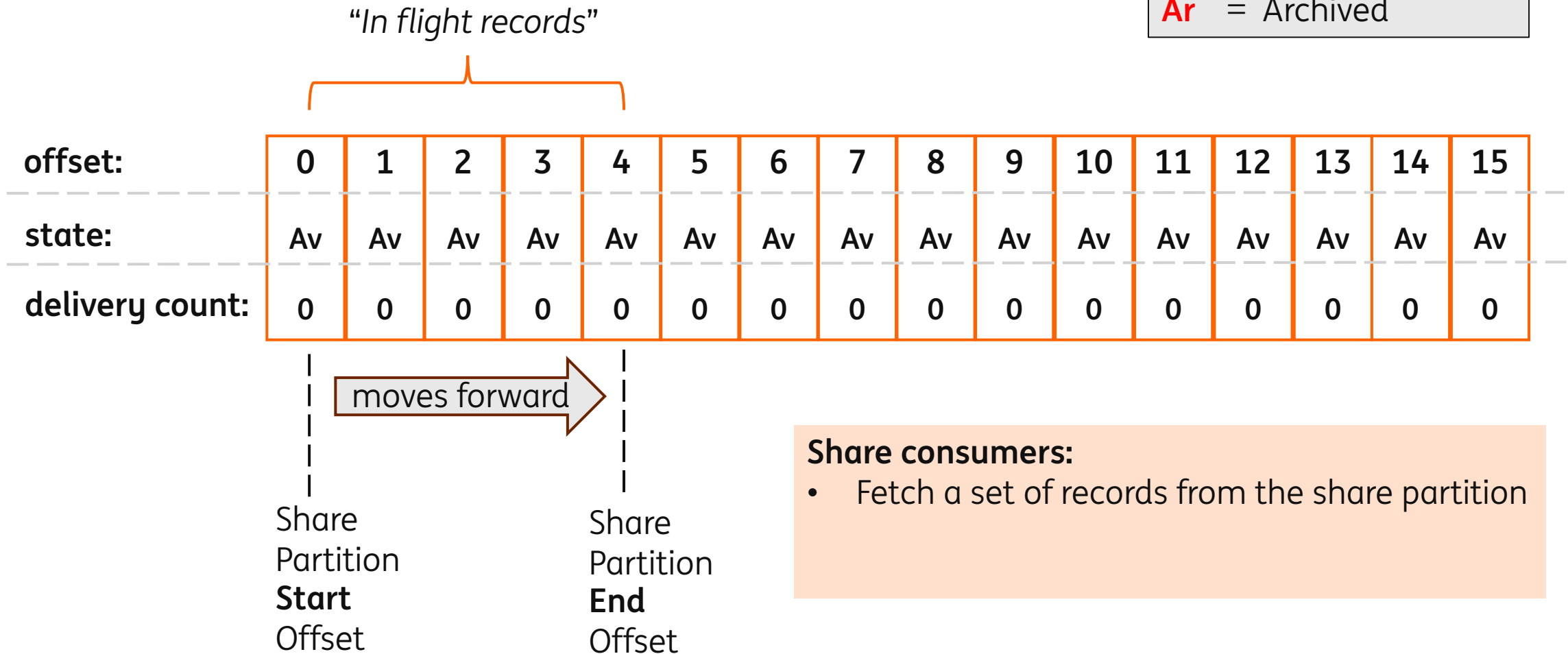

Queues for Kafka – How does it work?

Av = Available
Aq = Acquired
Ack = Acknowledge
Ar = Archived

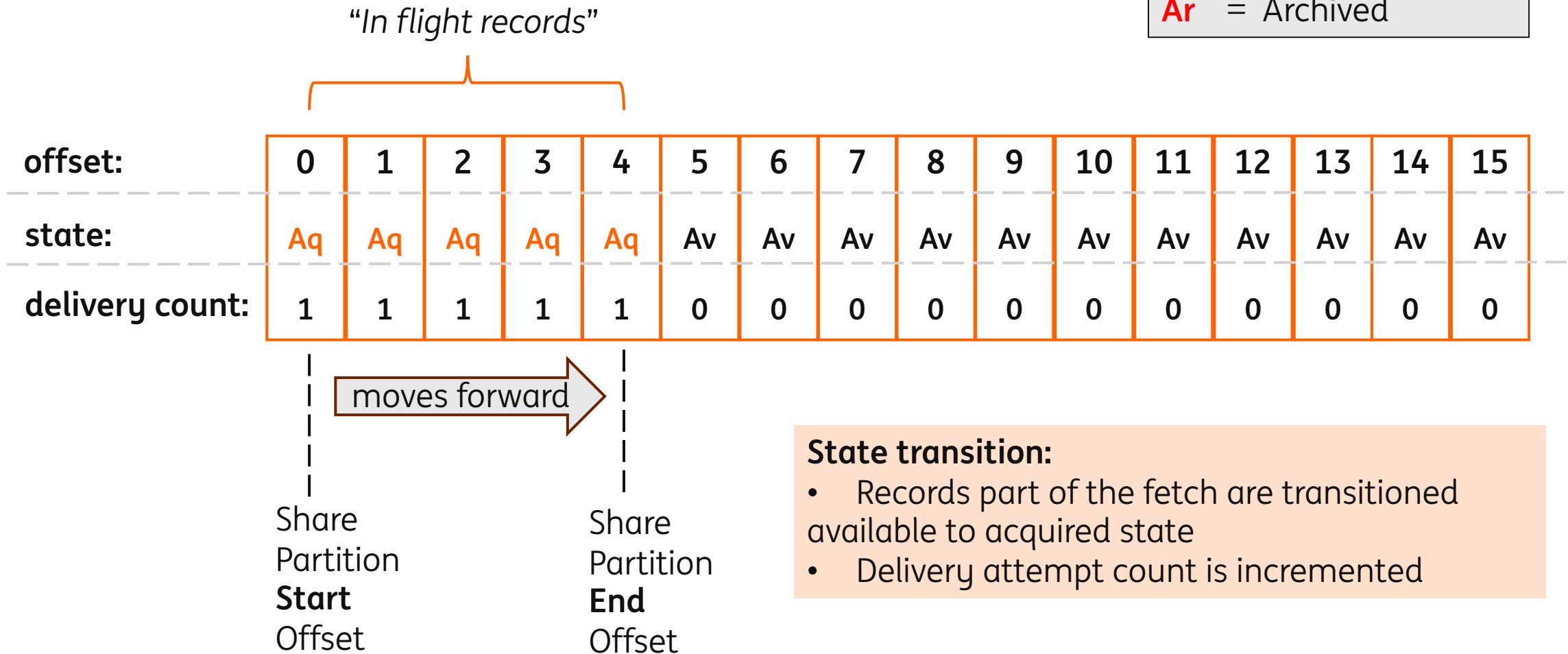

Queues for Kafka – How does it work?

Av = Available
Aq = Acquired
Ack = Acknowledge
Ar = Archived

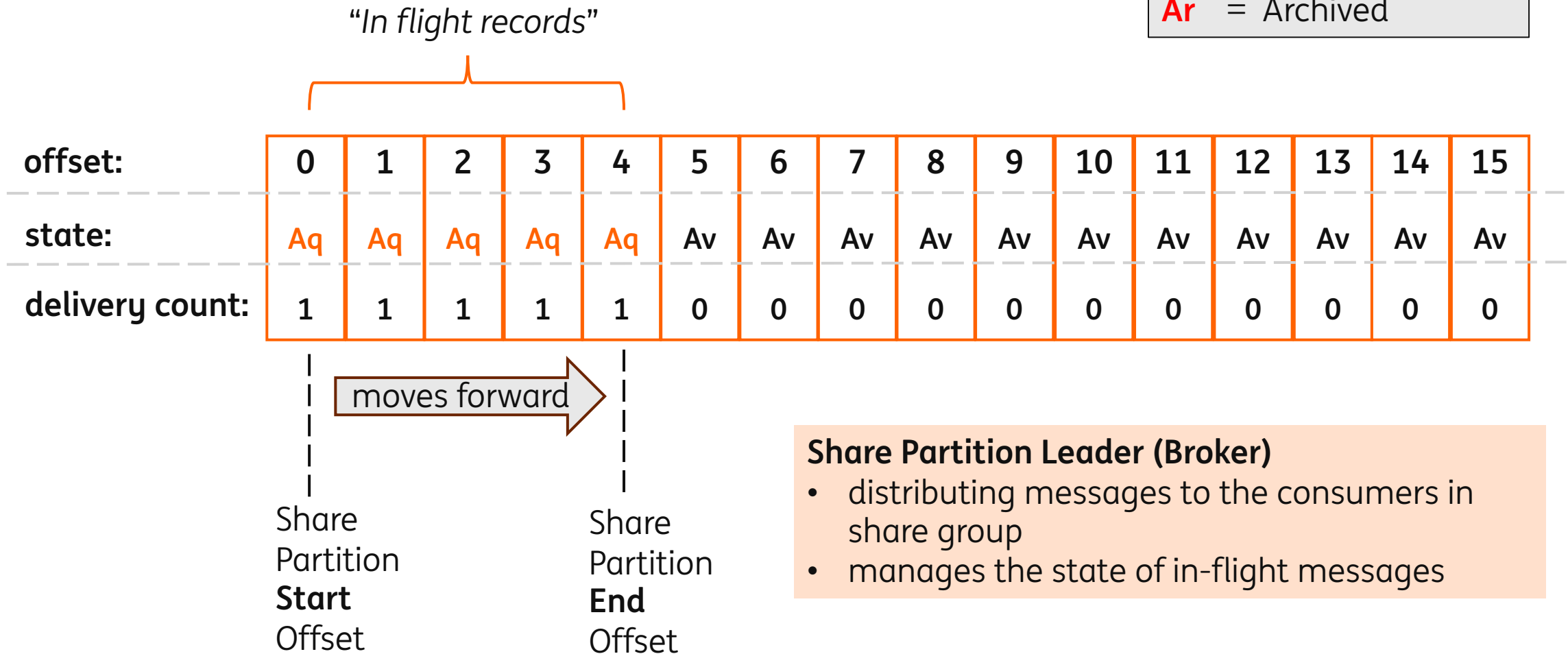

Queues for Kafka – How does it work?

Av = Available
Aq = Acquired
Ack = Acknowledge
Ar = Archived

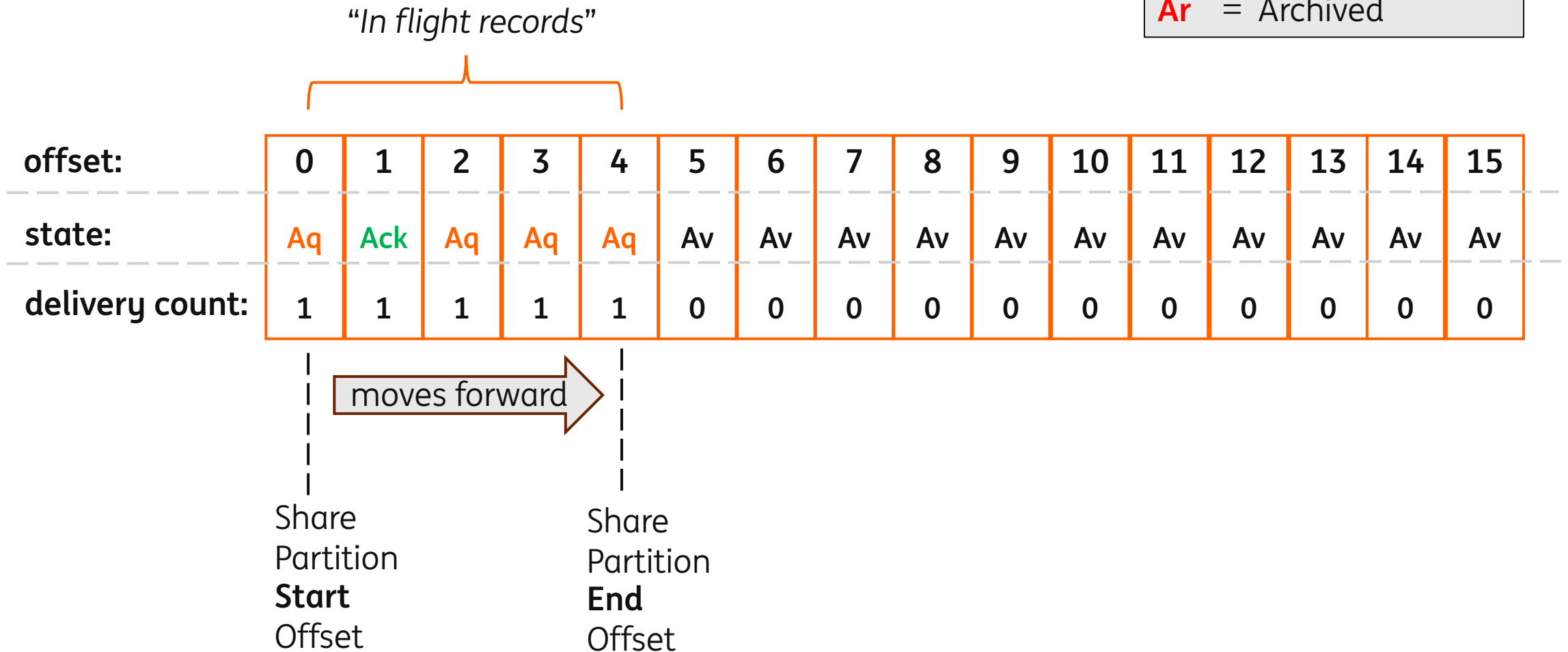

Queues for Kafka – How does it work?

Av = Available
Aq = Acquired
Ack = Acknowledge
Ar = Archived

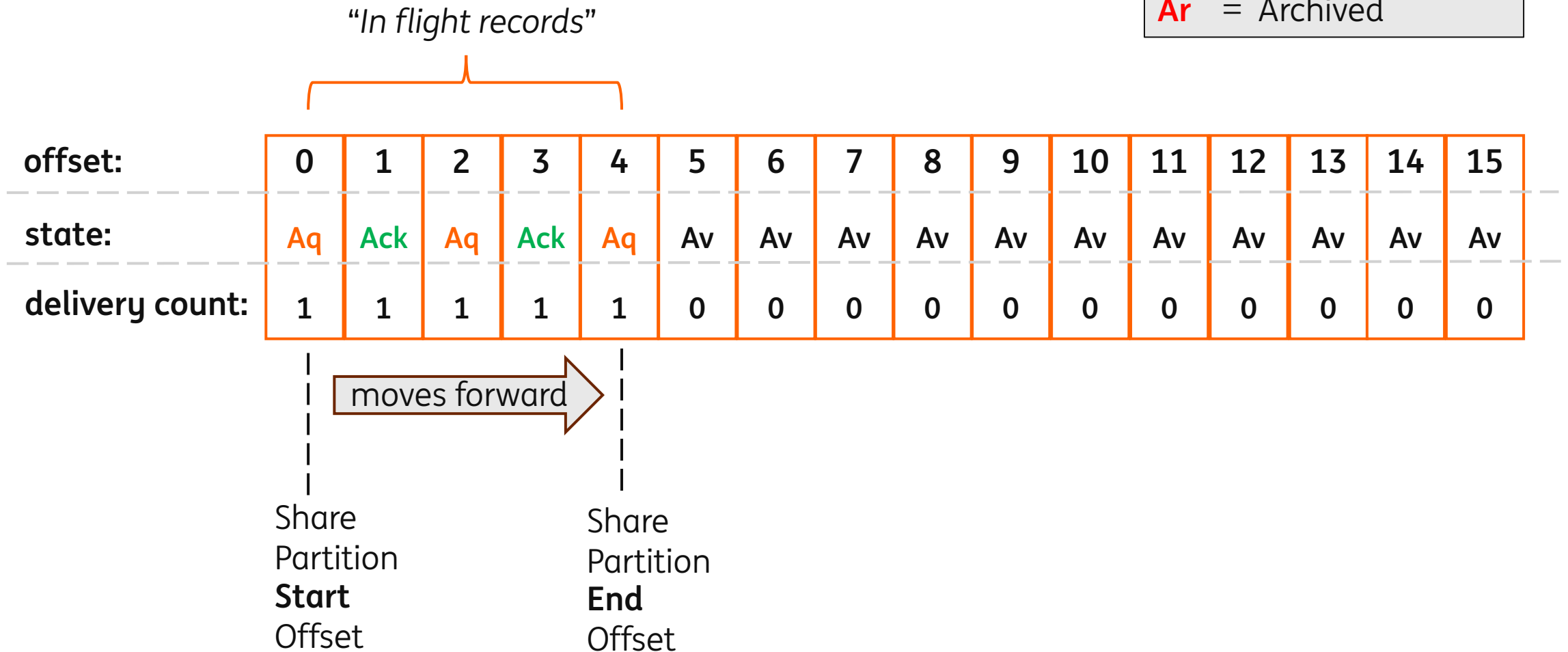

Queues for Kafka – How does it work?

Av = Available
Aq = Acquired
Ack = Acknowledge
Ar = Archived

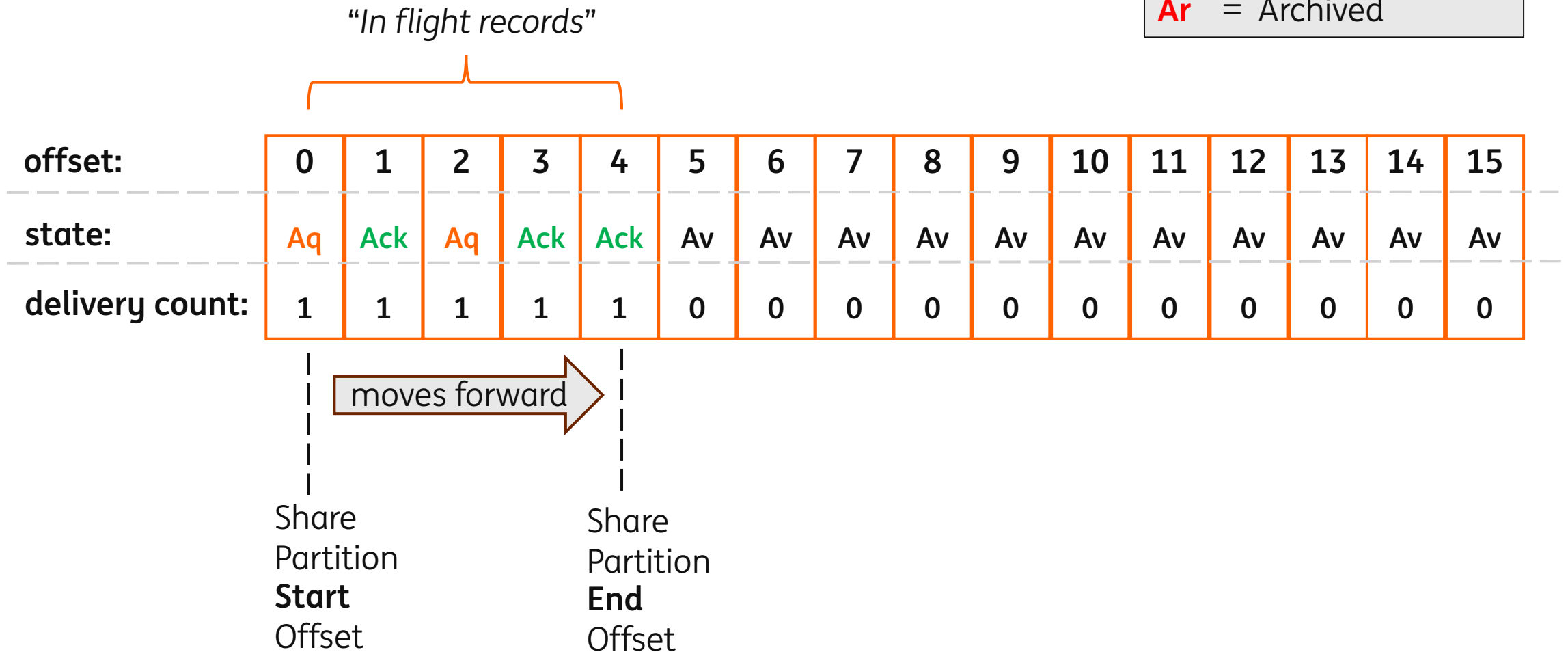

Queues for Kafka – How does it work?

Av = Available
Aq = Acquired
Ack = Acknowledge
Ar = Archived

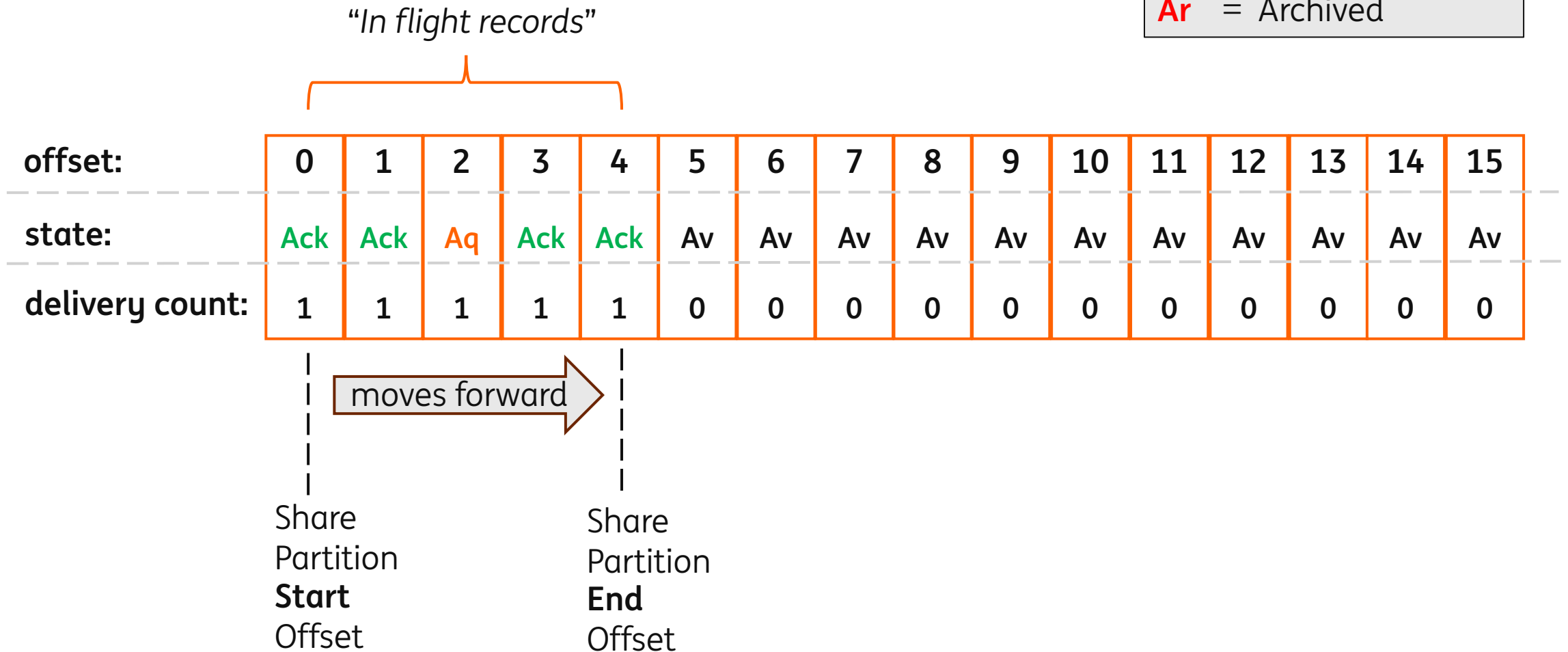

Queues for Kafka – How does it work?

Av = Available
Aq = Acquired
Ack = Acknowledge
Ar = Archived

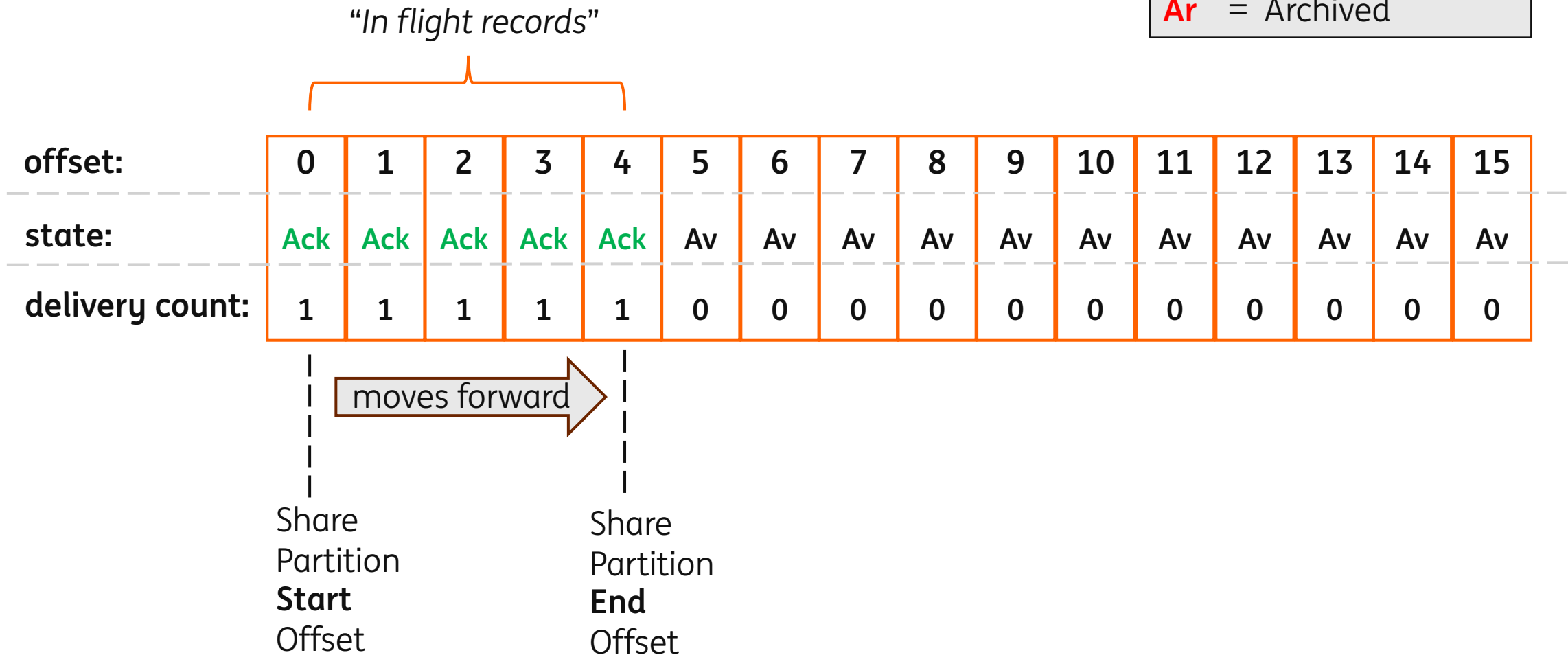

Queues for Kafka – How does it work?

Av = Available
Aq = Acquired
Ack = Acknowledge
Ar = Archived

"In flight records"

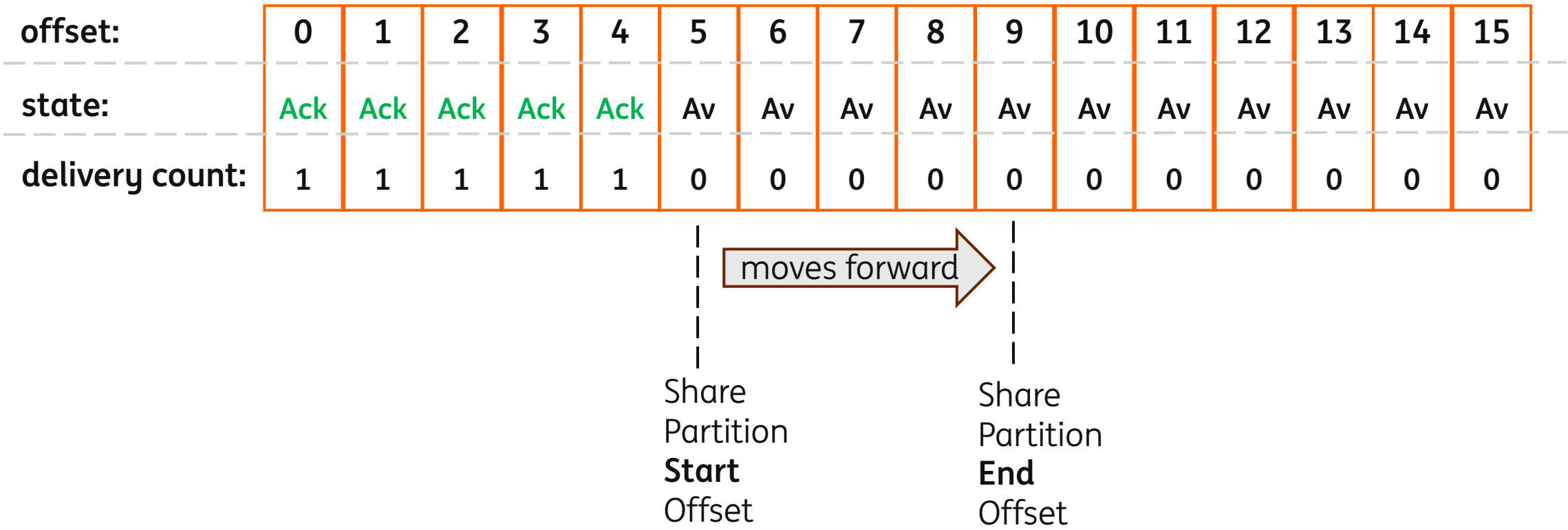

Queues for Kafka – How does it work?

Av = Available
Aq = Acquired
Ack = Acknowledge
Ar = Archived

"In flight records"

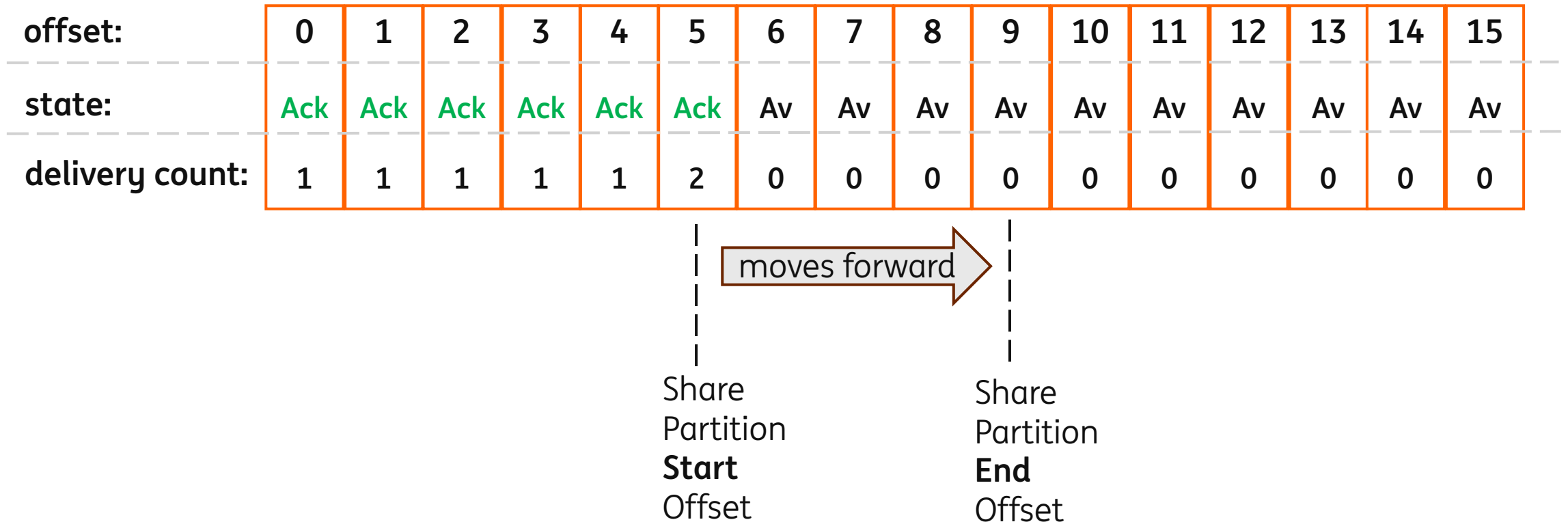

Queues for Kafka – How does it work?

Av = Available
Aq = Acquired
Ack = Acknowledge
Ar = Archived

“In flight records”

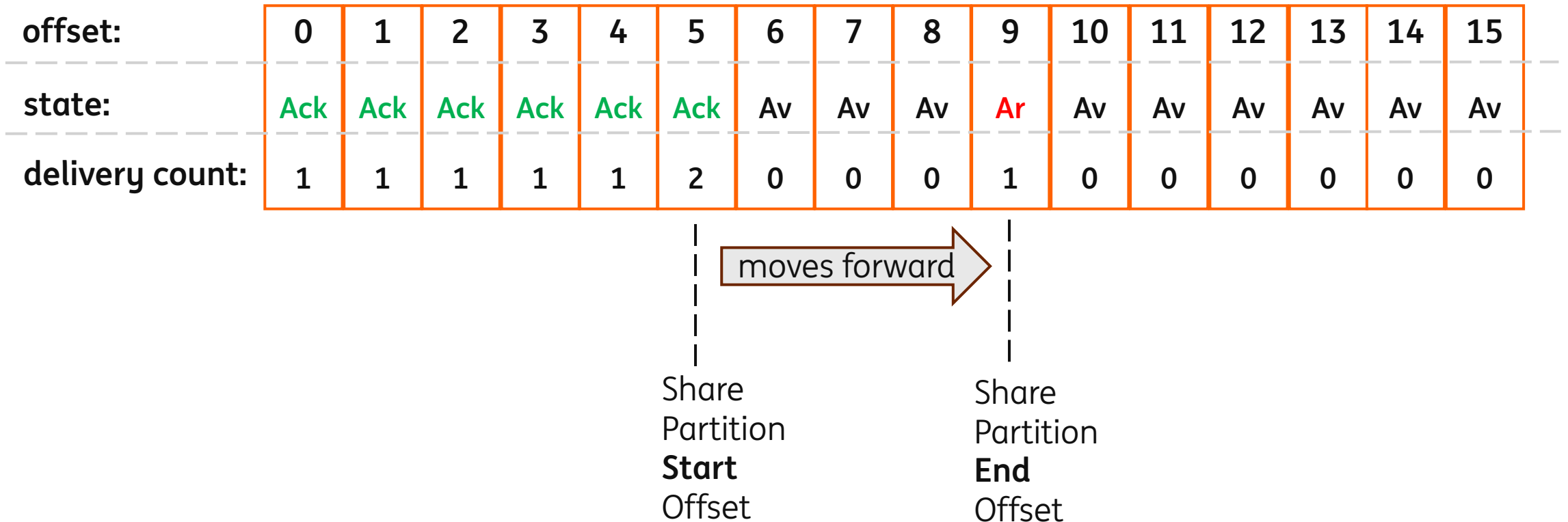

Queues for Kafka – How does it work?

Av = Available
Aq = Acquired
Ack = Acknowledge
Ar = Archived

"In flight records"

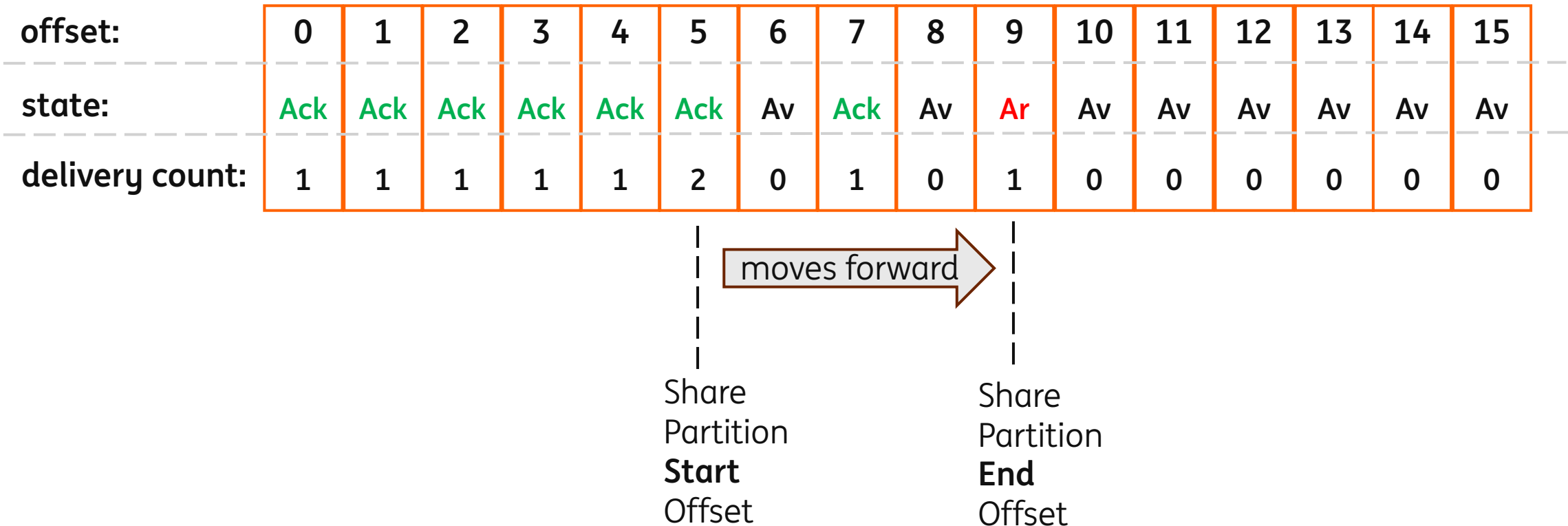

Queues for Kafka – How does it work?

Av = Available
Aq = Acquired
Ack = Acknowledge
Ar = Archived

"In flight records"

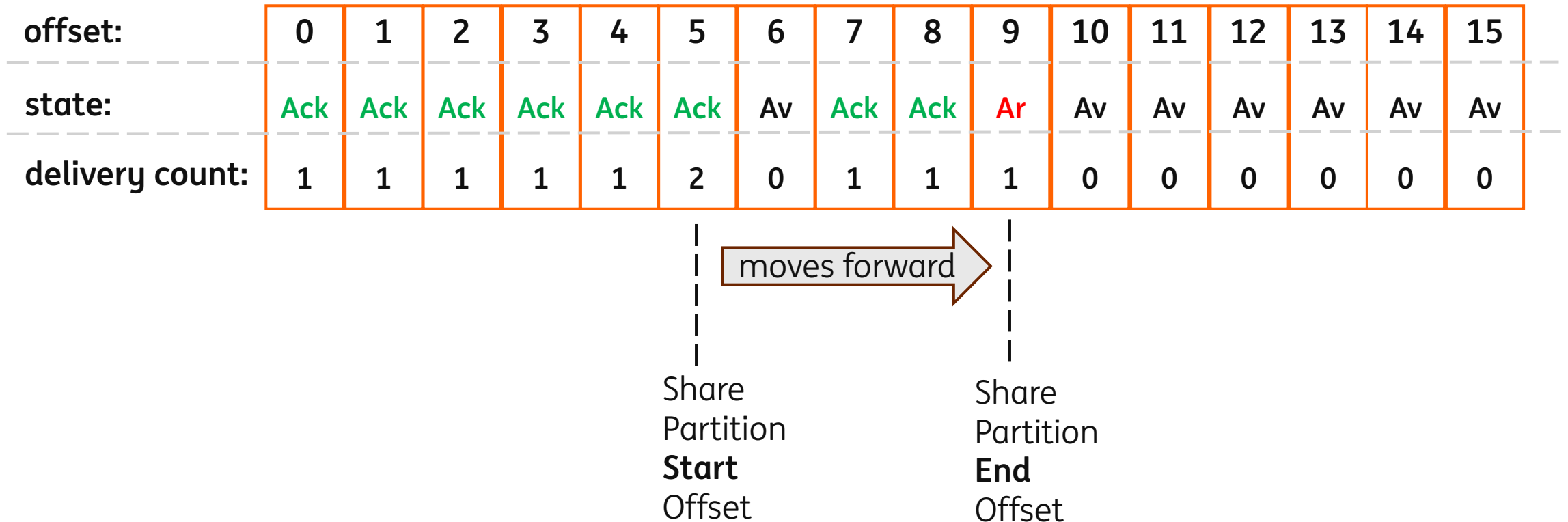

Queues for Kafka – How does it work?

Av = Available
Aq = Acquired
Ack = Acknowledge
Ar = Archived

"In flight records"

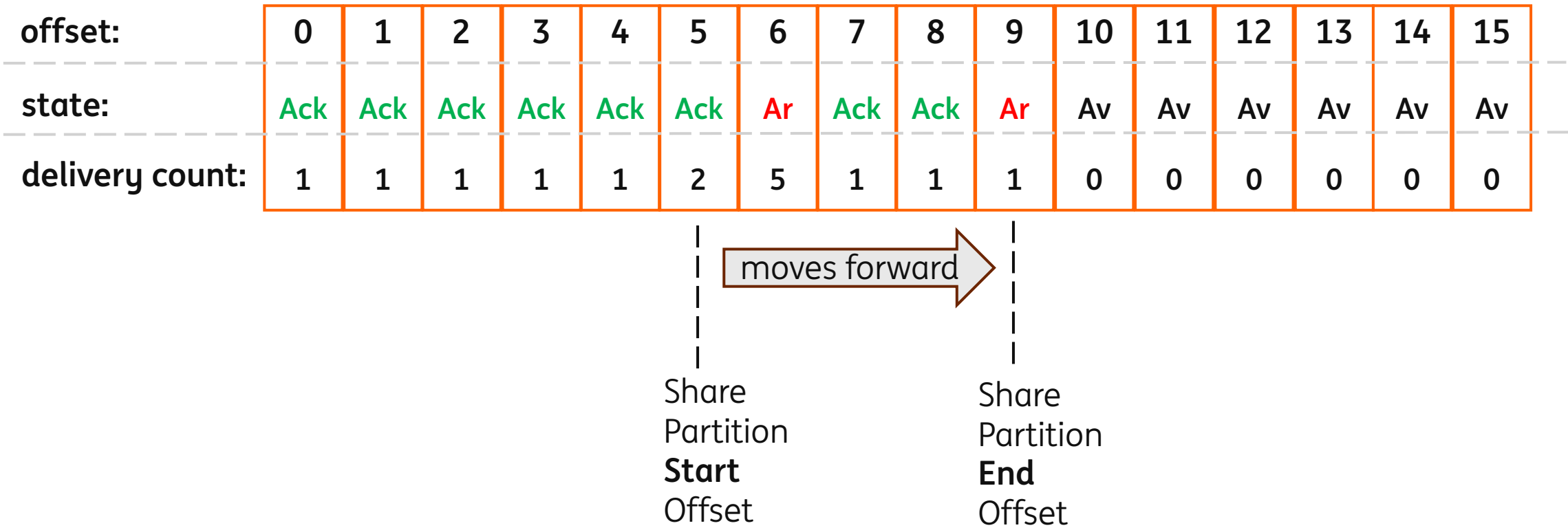

Queues for Kafka – How does it work?

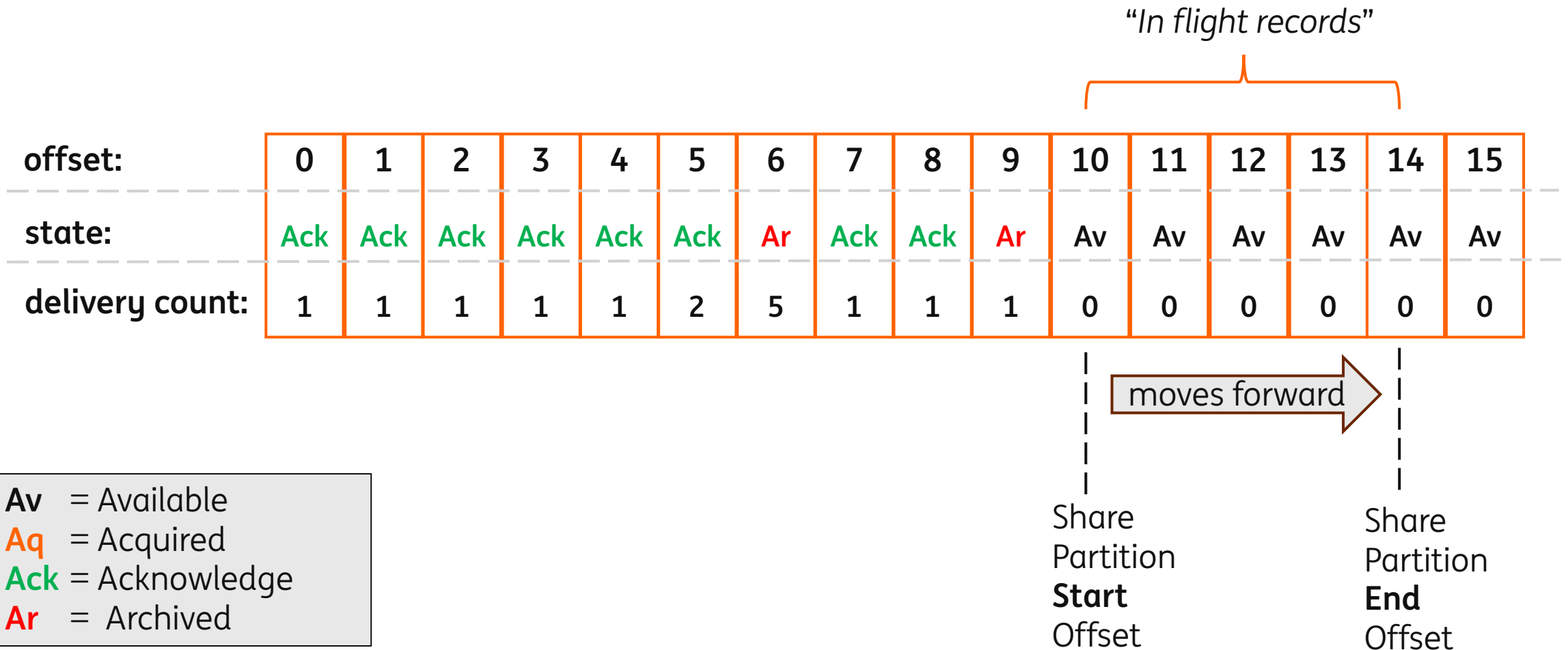

Queues for Kafka – How does it work?

Share Acknowledge Mode (Spring Kafka 4.1.x):

Mode	Who acknowledges?	On success	On error
Explicit (default)	Spring Kafka	ACCEPT	REJECT
Implicit	Broker auto-accepts	ACCEPT	ACCEPT (no recovery)
Manual	Your code	acknowledge() -> ACCEPT	release() -> AVAILABLE reject() -> REJECT

Queues for Kafka – Spring for Apache Kafka

- Important configurations
- Acknowledgment (Explicit, **Manual**, Implicit)
- Scaling
- Limitations

KIP-932

Queues for Kafka (Share Consumers)

In action



Queues for Kafka – Trade-offs

	Consumer Group	Share Group
Pattern	Event streaming / stream processing	Point to point Queue like messaging (Unit of work)

	Consumer Group	Share Group
Process (next message) in paralell	✗	✓
Scaling flexibility	✗ Low: (one to one ratio)	✓ High: (one to many ratio)
Queue semantics	✗	✓

Queues for Kafka – Trade-offs

	Consumer Group	Share Group
Pattern	Event streaming / stream processing	Point to point Queue like messaging

	Consumer Group	Share Group
Ordering guarantees	✓ *	✗
Fetch from follower	✓	✗
Static partition assignment	✓	✗
Topic patterns (regex)	✓	✗
Consume in batches	✓	✗

* Requires partitioning by a key

KIP-848:
The Next Generation
of the Consumer
Rebalance Protocol

Next Generation of the Consumer Rebalance Protocol

The “classic” consumer rebalance protocol

- Mechanism that coordinates:
 - which partitions are assigned
 - to which consumers within a group
- Rebalance occurs when:
 - Consumer side: group member joins / leaves the group
 - Cluster side: increase number of partitions
- Expensive operation
- Stop the world rebalances

Next Generation of the Consumer Rebalance Protocol

The “classic” consumer rebalance protocol

Can become problematic:

- Topic many partitions
- Large consumer groups

- Can't afford consumption interruption
- Environments with frequent rebalances
 - Auto scaling (Kubernetes)
 - Frequent deployments

Next Generation of the Consumer Rebalance Protocol

	Classic	Consumer
	Legacy mechanism, since the early version of Kafka	Fully redesigned protocol introduced in Kafka 4.0

Next Generation of the Consumer Rebalance Protocol

	Classic	Consumer
	Legacy mechanism, since the early version of Kafka	Fully redesigned protocol introduced in Kafka 4.0
Assignment Strategy	Controlled by consumers	Controlled by broker

Next Generation of the Consumer Rebalance Protocol

	Classic	Consumer
	Legacy mechanism, since the early version of Kafka	Fully redesigned protocol introduced in Kafka 4.0
Assignment Strategy	Controlled by consumers	Controlled by broker
Rebalance logic	Logic lives mostly on the consumer	Logic moved to the broker-side group coordinator

Next Generation of the Consumer Rebalance Protocol

	Classic	Consumer
	Legacy mechanism, since the early version of Kafka	Fully redesigned protocol introduced in Kafka 4.0
Assignment Strategy	Controlled by consumers	Controlled by broker
Rebalance logic	Logic lives mostly on the consumer	Logic moved to the broker-side group coordinator
Stop the world rebalance	Y *	N

* Assignment: *Eager* = full stop the world, *Cooperative* = partial stop the world

Next Generation of the Consumer Rebalance Protocol

	Classic	Consumer
	Legacy mechanism, since the early version of Kafka	Fully redesigned protocol introduced in Kafka 4.0
Assignment Strategy	Controlled by consumers	Controlled by broker
Rebalance logic	Logic lives mostly on the consumer	Logic moved to the broker-side group coordinator
Stop the world rebalance	Y *	N
Performance of rebalance	Slower	Faster

* Assignment: *Eager* = full stop the world, *Cooperative* = partial stop the world

Next Generation of the Consumer Rebalance Protocol

	Classic	Consumer
	Legacy mechanism, since the early version of Kafka	Fully redesigned protocol introduced in Kafka 4.0
Assignment Strategy	Controlled by consumers	Controlled by broker
Rebalance logic	Logic lives mostly on the consumer	Logic moved to the broker-side group coordinator
Stop the world rebalance	Y *	N
Performance of rebalance	Slower	Faster
Configuration property	group.protocol= classic	group.protocol= consumer

* Assignment: *Eager* = full stop the world, *Cooperative* = partial stop the world

Next Generation of the Consumer Rebalance Protocol

New consumer protocol

- Backward compatible
- By default the Kafka client (version 4) will keep using the 'classic'
- Will become the default in future releases of Kafka

Next Generation of the Consumer Rebalance Protocol

Upgrade path: Rolling upgrade of consumer instances (no downtime)

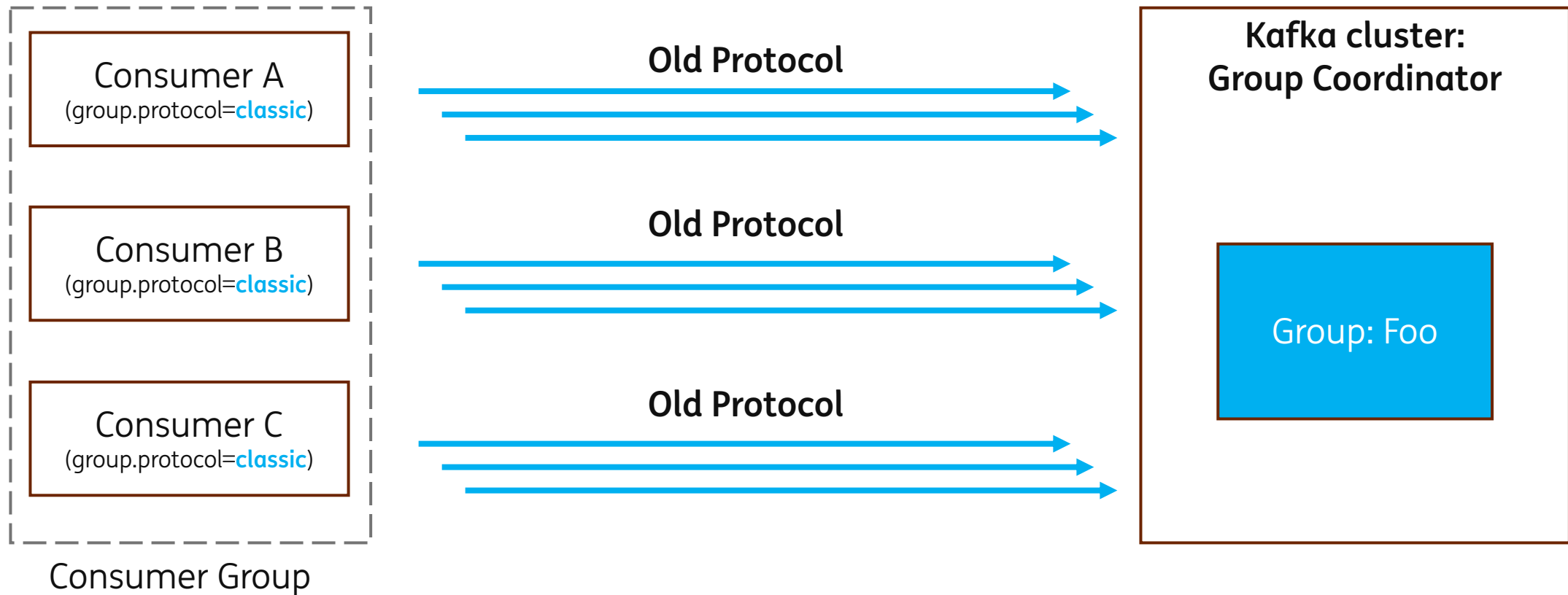

Next Generation of the Consumer Rebalance Protocol

Upgrade path: Rolling upgrade of consumer instances (no downtime)

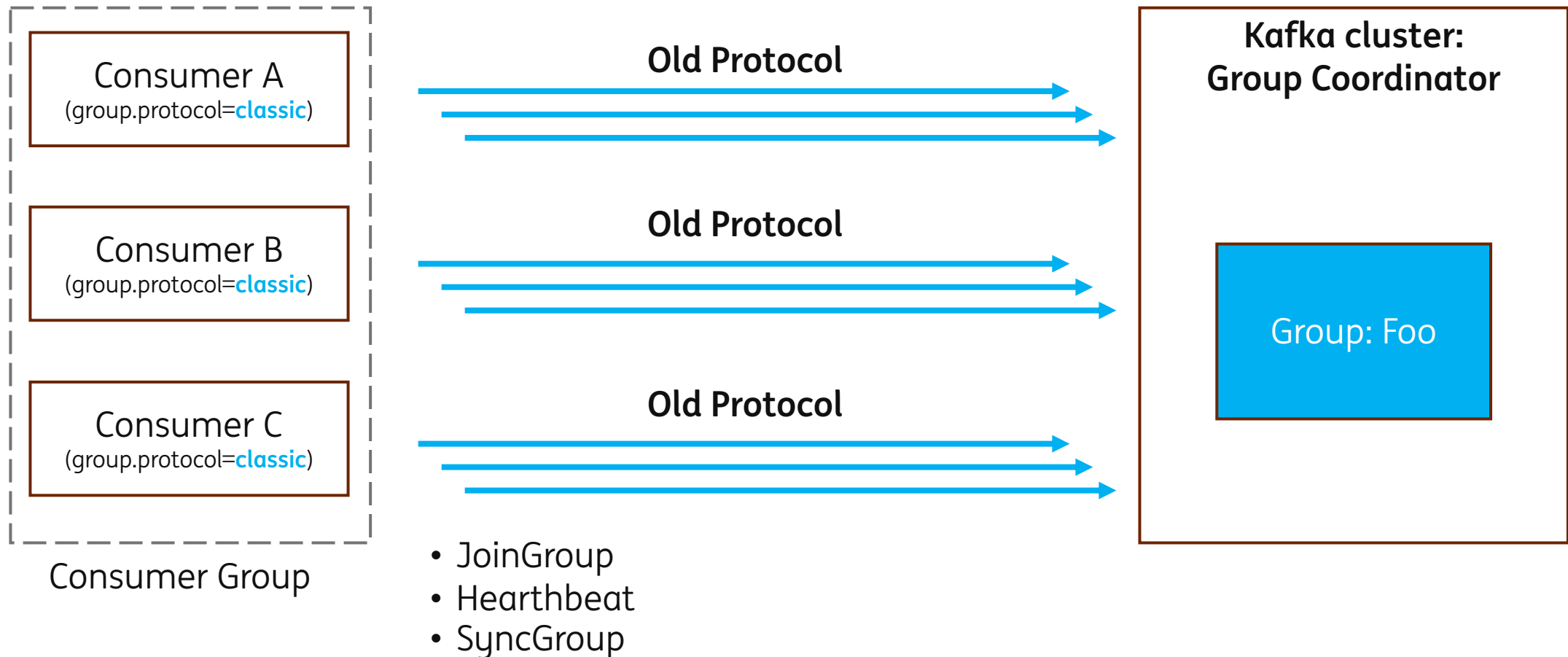

Next Generation of the Consumer Rebalance Protocol

Upgrade path: first consumer configured with new protocol joins an existing classic group

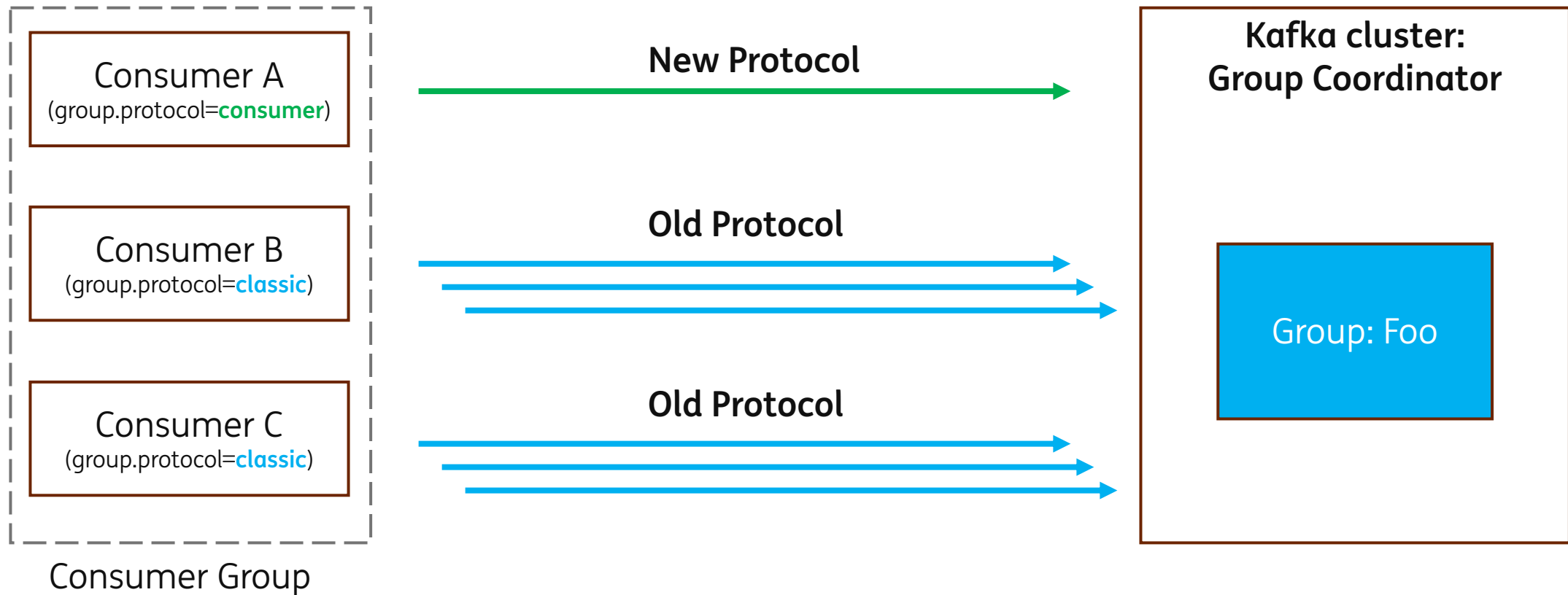

Next Generation of the Consumer Rebalance Protocol

Upgrade path: Group coordinator automatically transitions the group

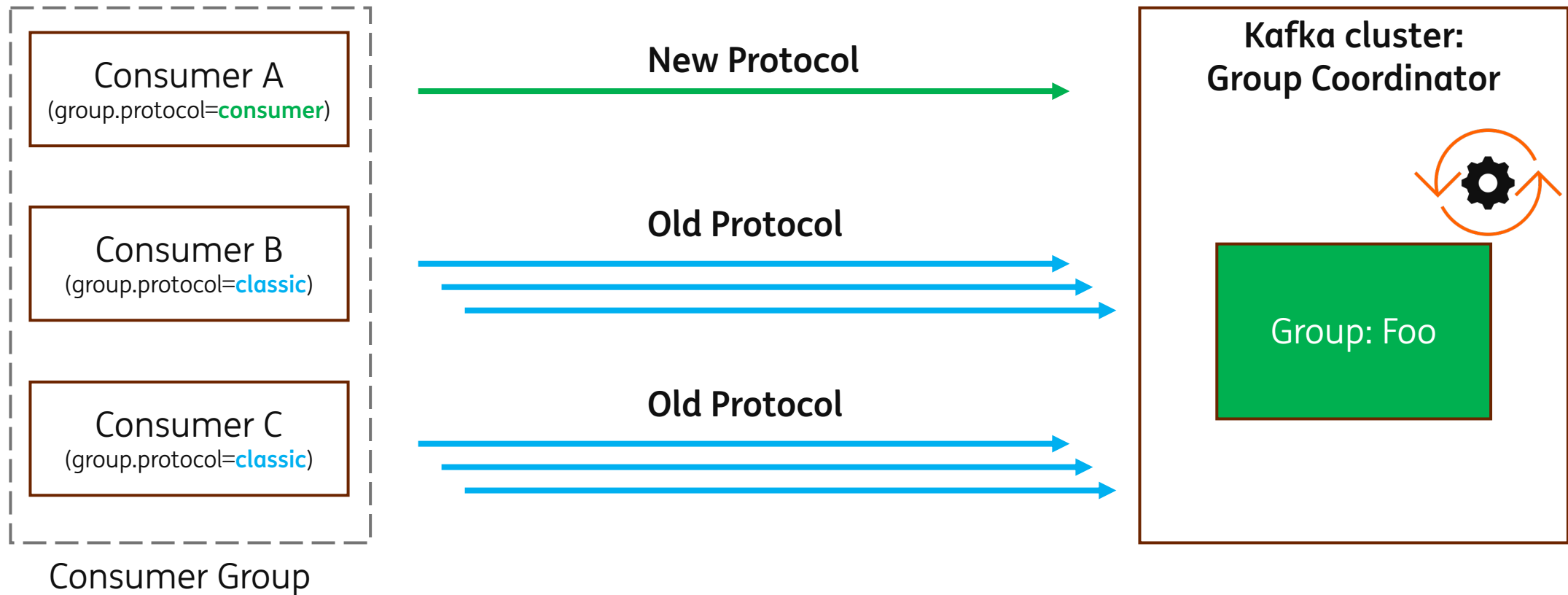

Next Generation of the Consumer Rebalance Protocol

Upgrade path: Mixing consumer rebalance protocols in the same consumer group is intended only for to support live upgrades!

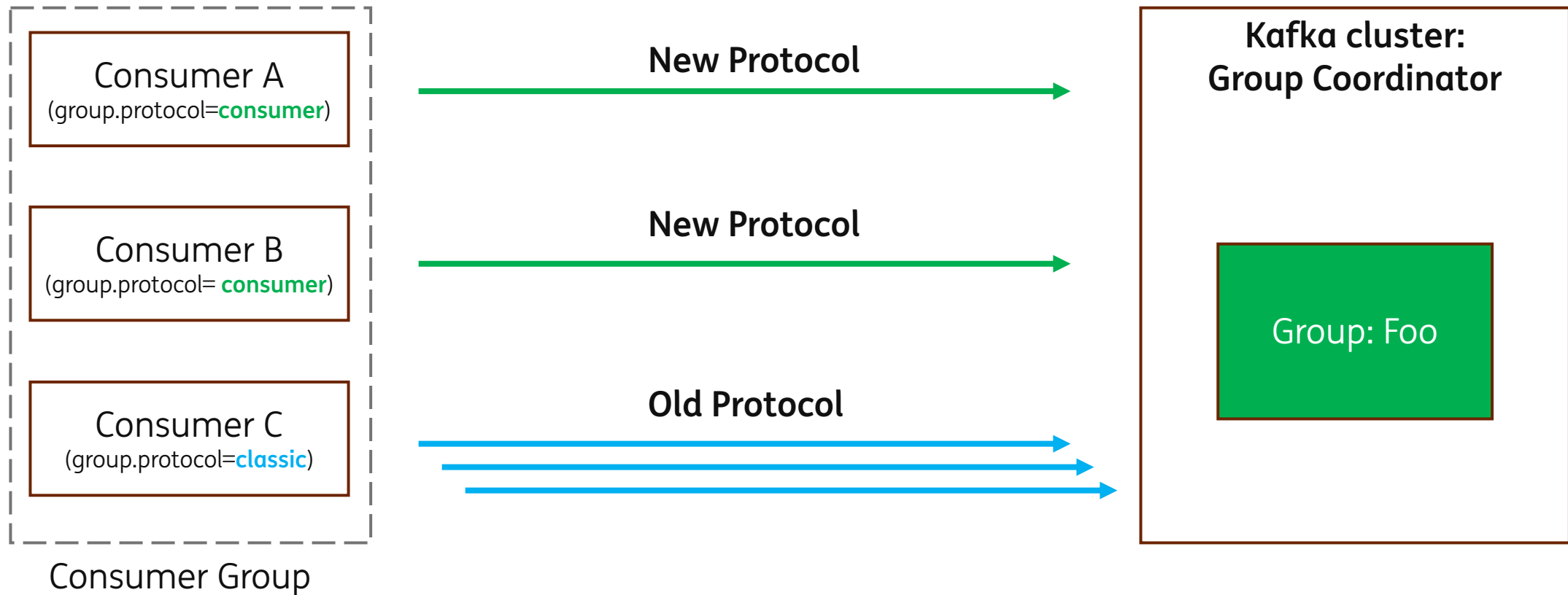

Next Generation of the Consumer Rebalance Protocol

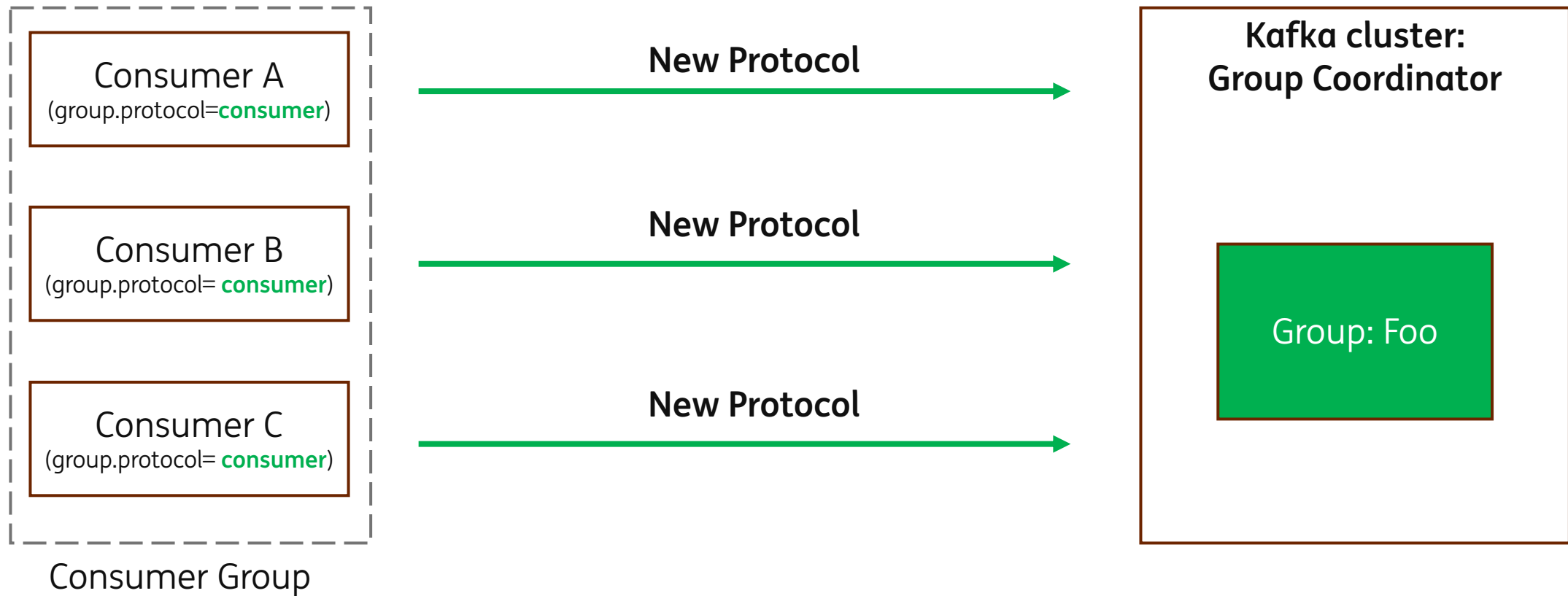

KIP-848:

**The Next Generation of the
Consumer Rebalance Protocol
In action**



Next Generation of the Consumer Rebalance Protocol

Trade-offs & Limitations:

- **Metrics: Kafka client side consumer**
 - **Different:** adapt monitoring and observability
 - Exposed using Spring Boot (/actuator/metrics)
- **Configuration**
 - Disables several classic consumer configurations, such as:
 - heartbeat.interval.ms
 - session.timeout.ms
 - partition.assignment.strategy
- **Custom assignment strategies** are not supported

Wrap-up

Wrap up - Queues for Kafka (Share Consumers)

- GA in: Kafka 4.2 (Spring Boot & Spring Kafka 4.1– May 2026)
- Share Groups are **NOT** a **replacement** for consumer groups
- **Alternative** consumption model
- **Queue like semantics**
- Key trade-off:
 - **Loss** of partial **ordering**
 - Not supported:
 - Follower Fetching
 - Static partition assignment
 - Subscribing to topics patterns (regex)

Wrap up - Migration Path to Spring Kafka 4

- Not too complicated
- Do it once yourself to understand all the changes
- Leverage OpenRewrite to automate your upgrade

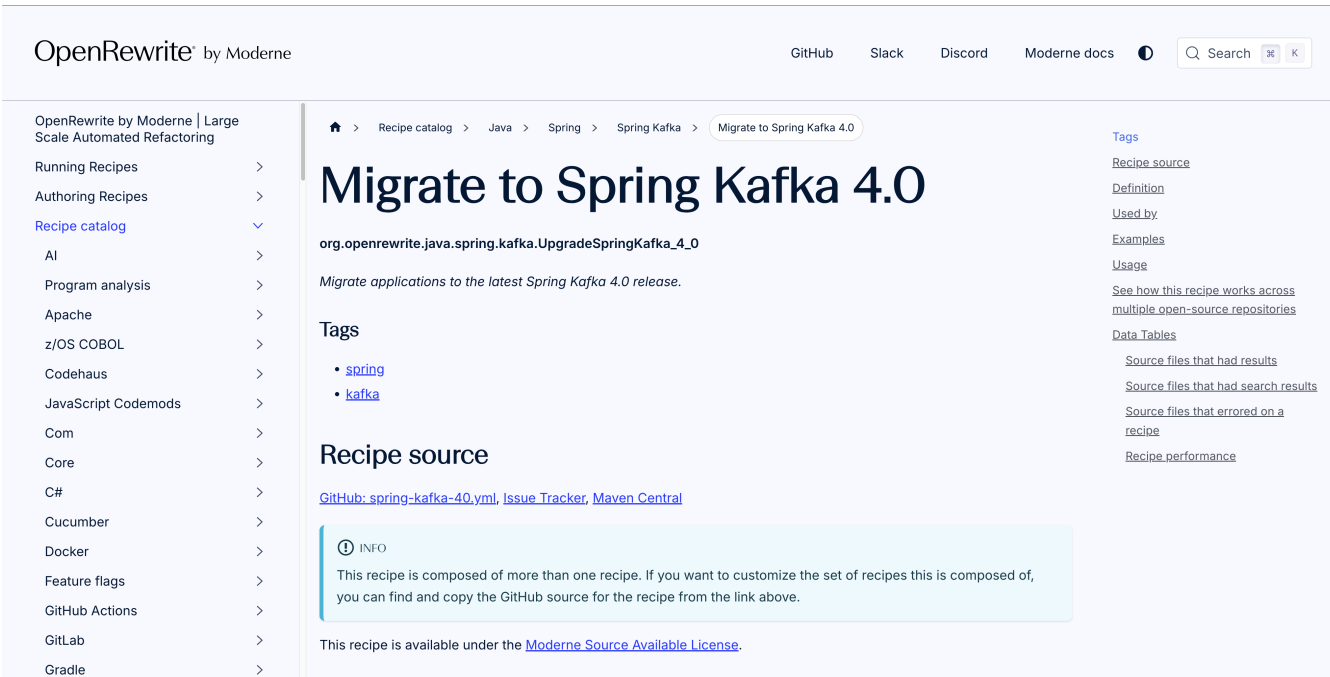

The screenshot shows the OpenRewrite website interface. At the top, there's a navigation bar with links for GitHub, Slack, Discord, and Moderne docs, along with a search bar. The main content area is titled 'Migrate to Spring Kafka 4.0' and includes a breadcrumb trail: 'Recipe catalog > Java > Spring > Spring Kafka > Migrate to Spring Kafka 4.0'. The page content includes the recipe name, a description, tags for 'spring' and 'kafka', and a 'Recipe source' section with links to GitHub, Issue Tracker, and Maven Central. A right-hand sidebar contains a 'Tags' section with various links like 'Recipe source', 'Definition', 'Used by', 'Examples', 'Usage', and 'Data Tables'. A light blue information box at the bottom states: 'This recipe is composed of more than one recipe. If you want to customize the set of recipes this is composed of, you can find and copy the GitHub source for the recipe from the link above.' Below this, it mentions the recipe is available under the 'Moderne Source Available License'.

Wrap up - Queues for Kafka (Share Consumers)

Spring Boot / Spring Kafka 4.0:

- Easy to get started
- First version
- Current Limitations:
 - No Autoconfiguration
 - No metrics and tracing
 - No exponential back-off for retries
 - No dead letter topic support

Wrap up - Next Generation Consumer Rebalance Protocol

- **Backward compatible**
- Consumers can **opt-in** via `group.protocol=consumer`
- Protocol is **more resilient**
- Shifting **complexity** to the **broker** makes Spring Kafka applications lighter
- **Live upgrade** possible (no downtime)
- Very **fast rebalances** for your Kafka consumers

- Custom assignment strategies are not supported
- New consumer metrics: impact on monitoring and observability

Questions?



Codebase Github:

<https://github.com/j-tim/spring-io-barcelona-2026-what-s-new-in-spring-kafka-4>



do your thing

Thank you!

www.ing.com

ING

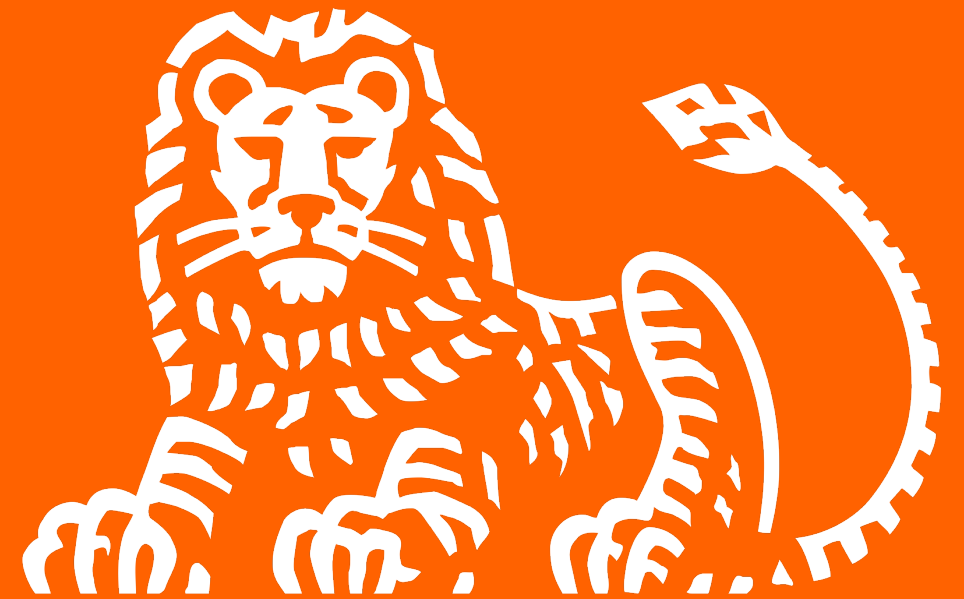

Chapter title running up to two lines

A smaller headline for this
chapter goes here.

Chapter title running up to two lines



**Chapter title running
up to two lines**



Very short Chapter title



A smiling man with a beard, wearing a teal t-shirt and brown pants, is sitting on a blue wooden chair in a garden. He is looking towards the camera. In the foreground, a hand is holding a carrot. The background is filled with green plants and a wooden trellis structure. The text "Optional title for this chapter divider" is overlaid in white, bold font across the center of the image.

**Optional title for this
chapter divider**



**This is where you
tell an interesting
story. Keep it
brief though!**

**This is some placeholder body copy that
you should either leave blank or replace.**

**This is where you
tell an interesting
story. Keep it brief
though!**

This is some placeholder body copy that
you should either leave blank or replace.

**This is where you
tell an interesting
story. Keep it brief
though!**

This is some placeholder body copy that
you should either leave blank or replace.

A large title or number of your story

This is some placeholder body copy that you should either leave blank or replace.

A large title or number of your story

This is some placeholder body copy that you should either leave blank or replace.

A large title or number of your story

This is some placeholder body copy that you should either leave blank or replace.

A large title or number of your story

This is some placeholder body copy that you should either leave blank or replace.

A large title or number of your story

This is some placeholder body copy that you should either leave blank or replace.

A large title or number of your story

This is some placeholder body copy that you should either leave blank or replace.

A large title or number of your story

This is some placeholder body copy that you should either leave blank or replace.

A large title or number of your story

This is some placeholder body copy that you should either leave blank or replace.

A large title or number of your story

This is some placeholder body copy that you should either leave blank or replace.

A large title or number of your story

This is some placeholder body copy that you should either leave blank or replace.





do your thing

Thank you!

www.ing.com

ING

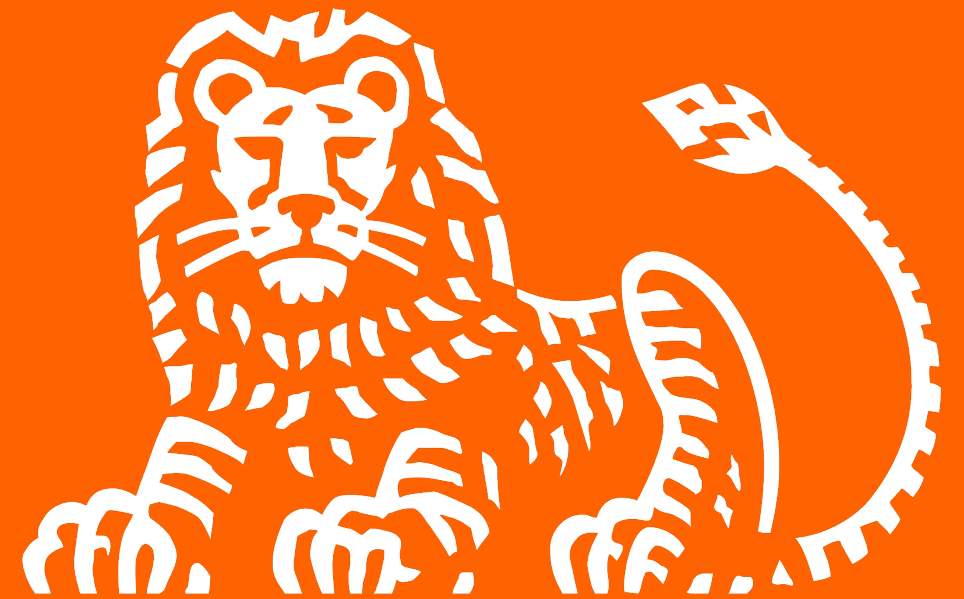

Iconography

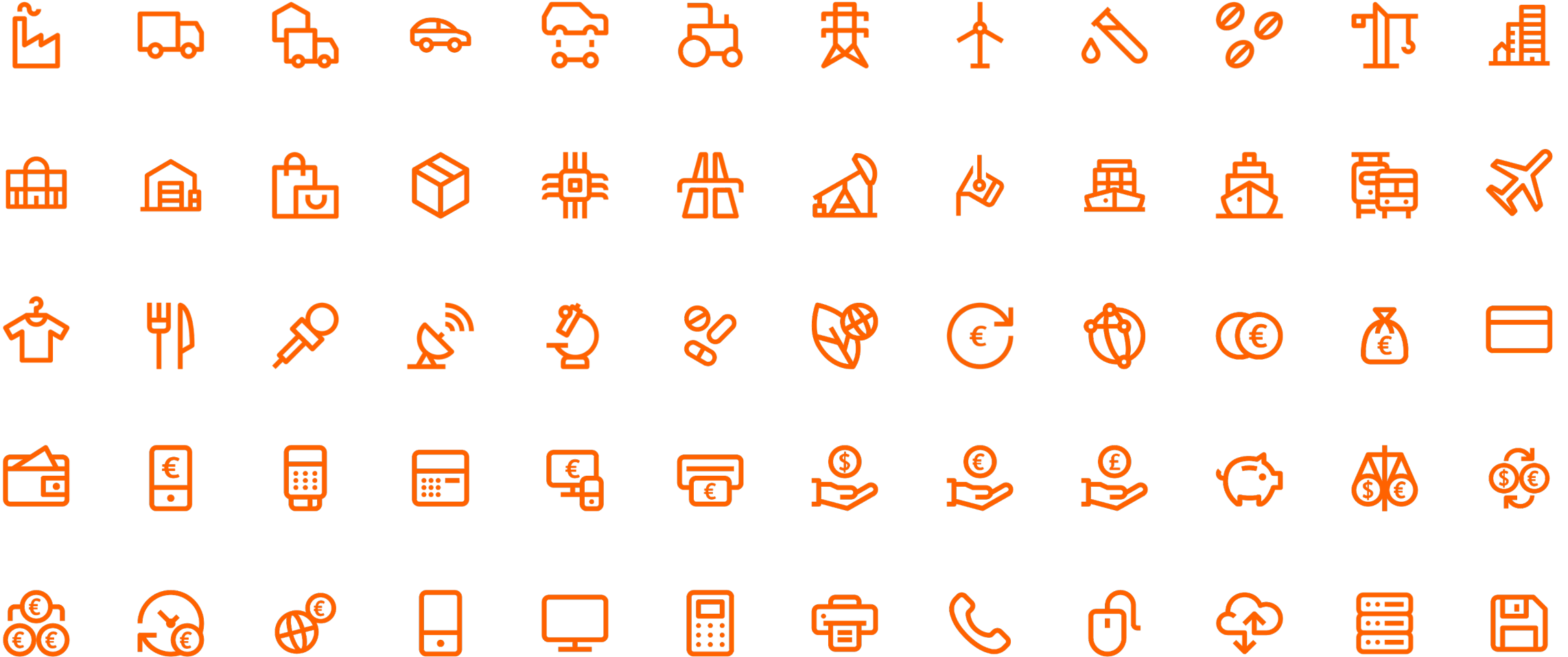

Iconography

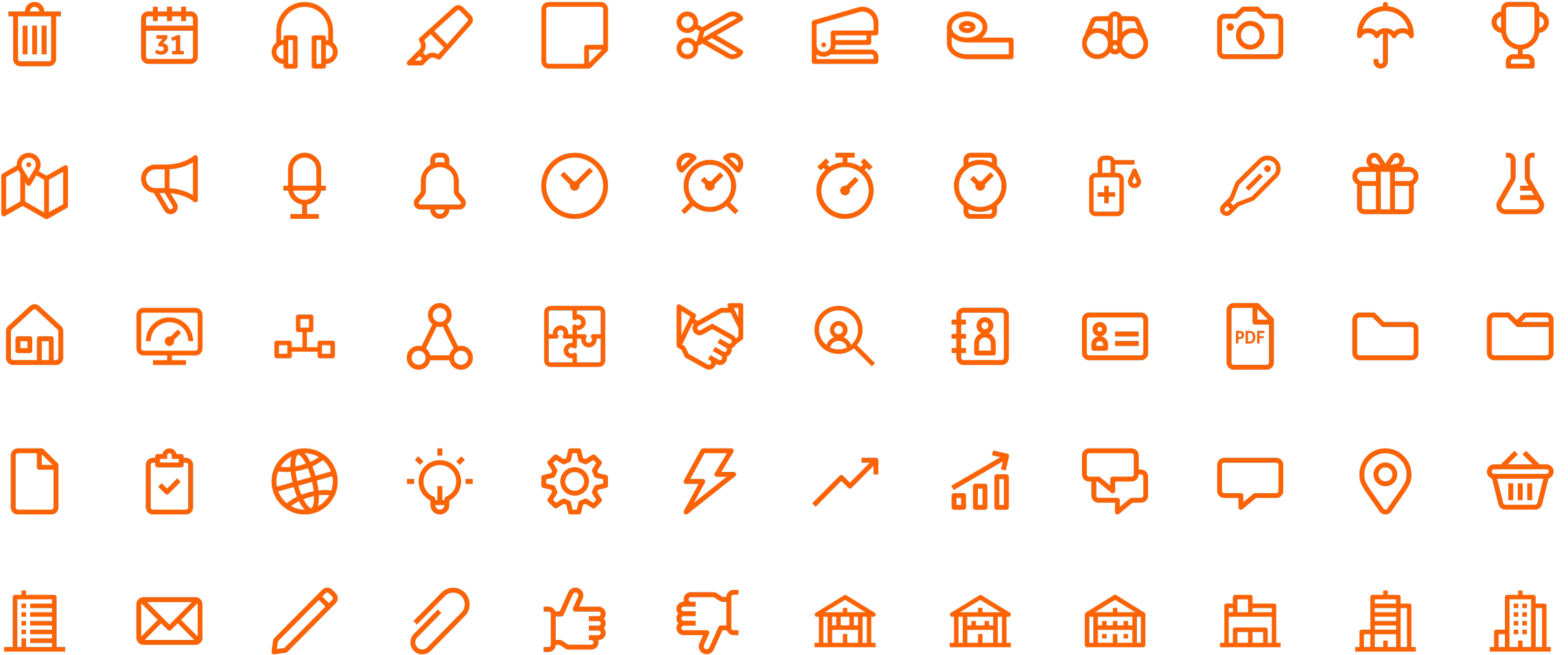

Iconography

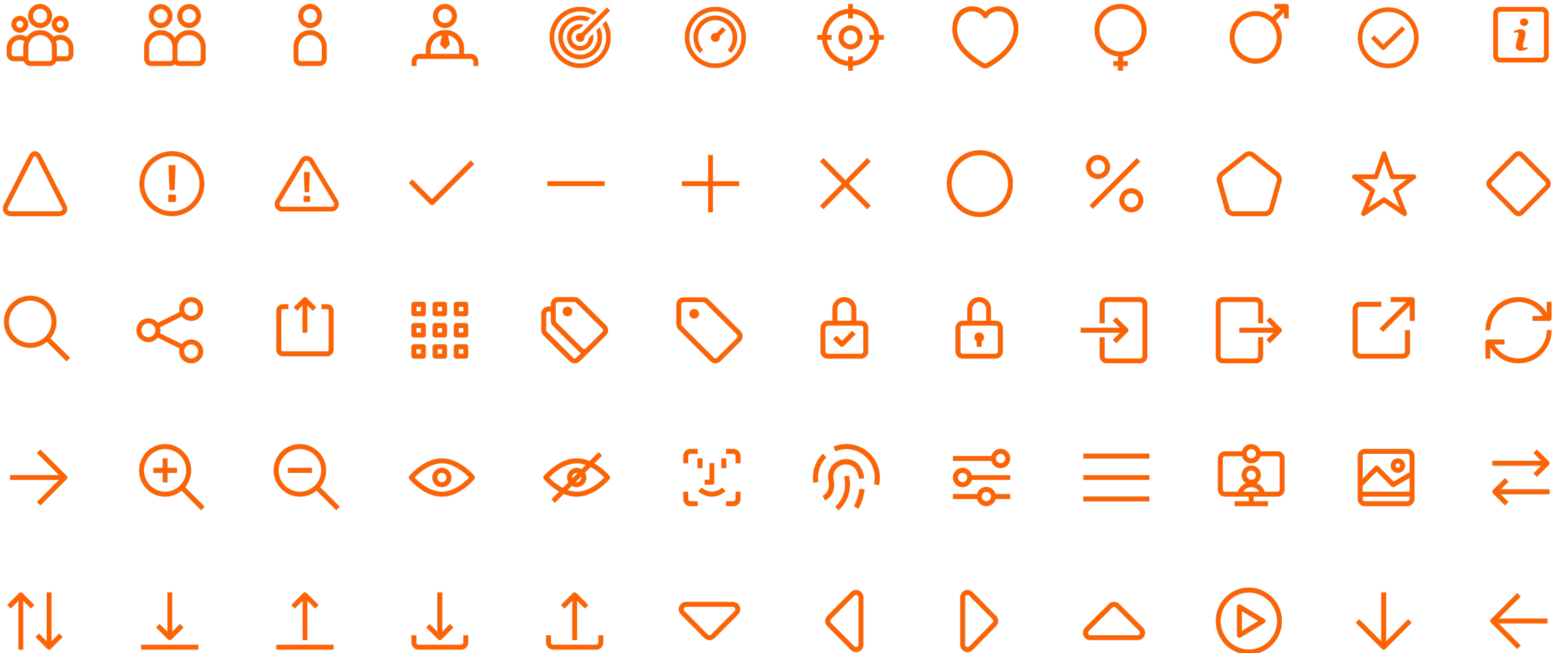

Iconography



You can find the current full set of icons in the Media bank on the [ING Brand site](#).

Iconography on background colours



Flags Europe



Austria



Belgium



Bulgaria



Czech Republic



France



Germany



Hungary



Ireland



Italy



Kazakhstan



Luxembourg



The Netherlands



Poland



Portugal



Romania

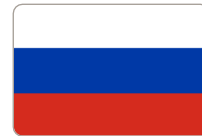

Russia



Slovakia



Spain



Sweden



Switzerland



Türkiye



Ukraine



United Kingdom

Flags Americas and Asia-Pacific



Argentina



Brazil



Mexico



United States
of America



Australia



Mainland China



India



Indonesia



Japan



Malaysia



The Philippines



Singapore



South Korea



Thailand



United Arab
Emirates



Vietnam

European map



World map



Our markets

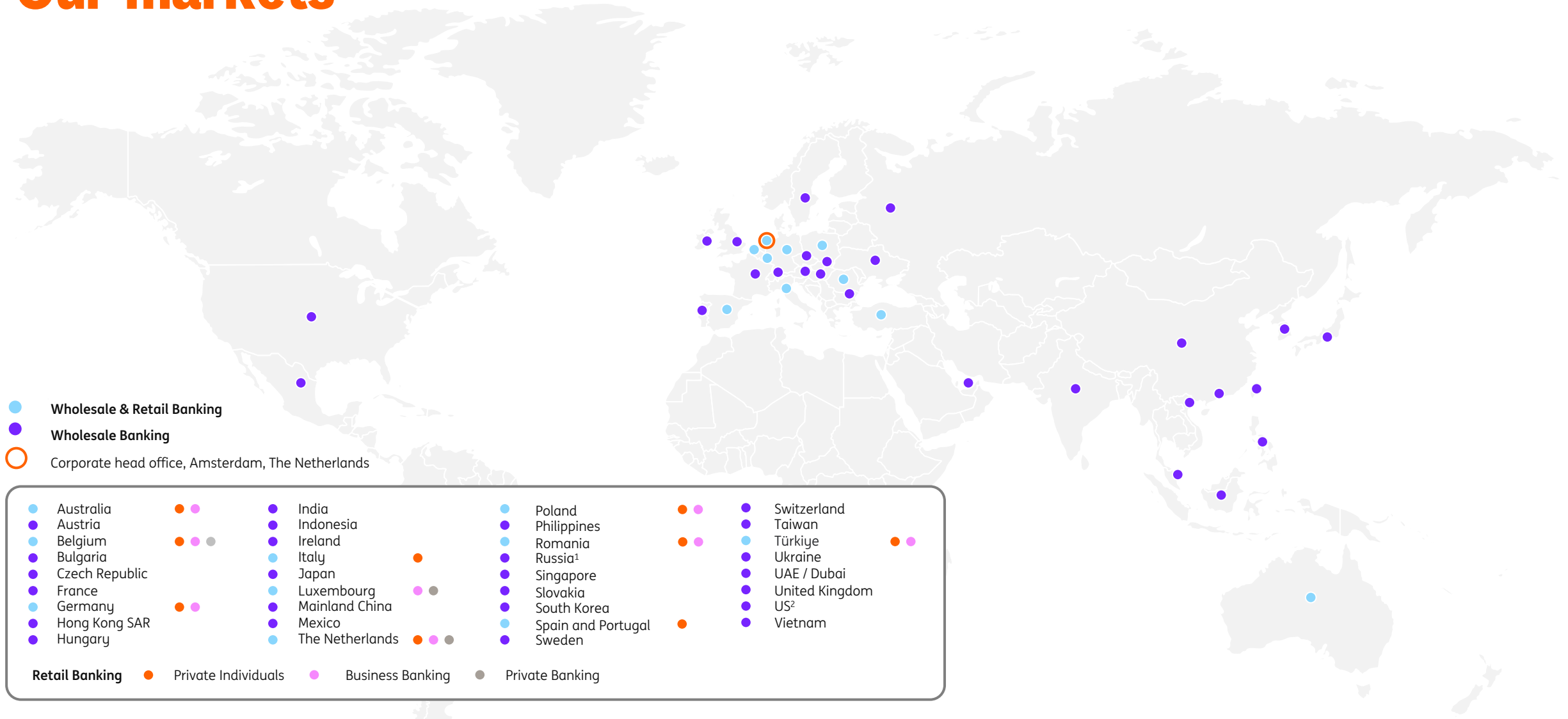

- (1) In January 2025, we announced that we have reached an agreement on the sale of our business in Russia to Global Development JSC. This transaction will effectively end ING's activities in the Russian market and is expected to close in the third quarter of 2025, following applicable regulatory approvals.
- (2) ING does not have a banking license in the US and therefore not permitted to conduct banking activities in the US. Through its wholly owned subsidiary ING Financial Holdings Corporation and its affiliates, ING offers a full array of wholesale financial products such as lending, corporate finance and a full range of financial markets products and services to its corporate and institutional clients.

Timeline

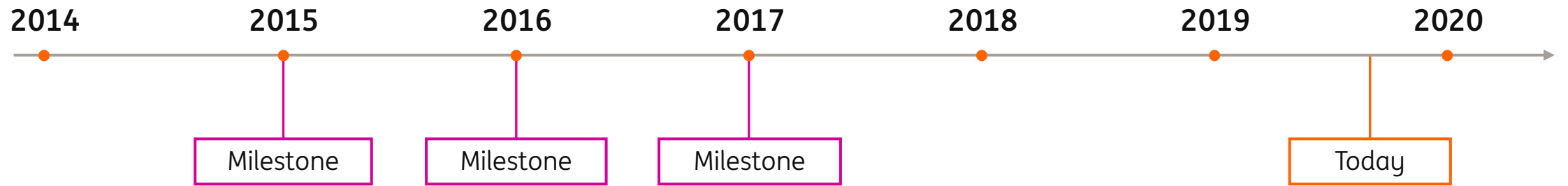

Organisational chart

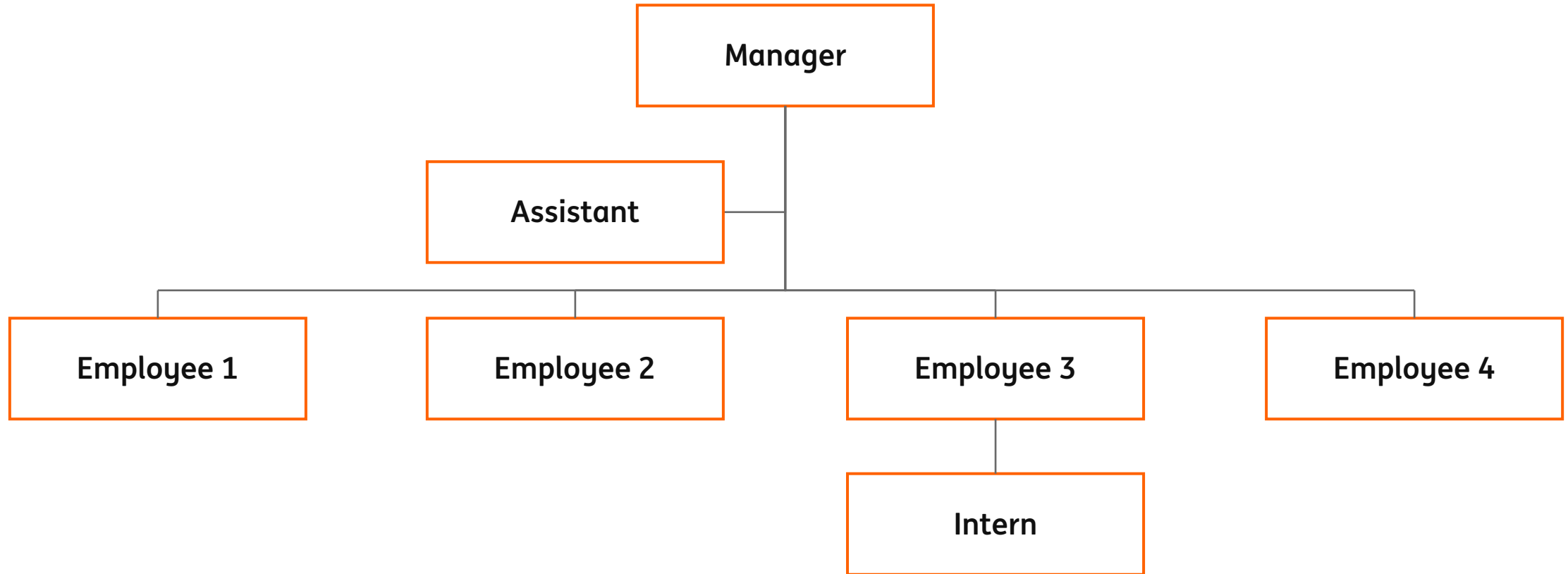

Assorted elements

Finished	
Payments	
Aaa	✗
Bbb	✓
Ccc	✗
Collections	
Ddd	✓
Eee	✓
Fff	✗



Text box

Text box

Text box

Text box

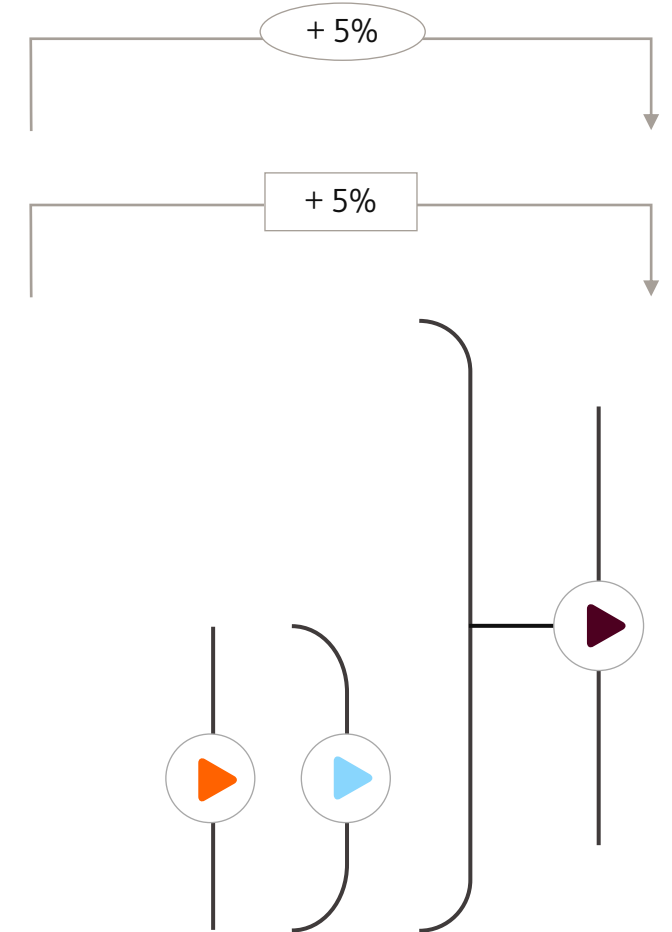
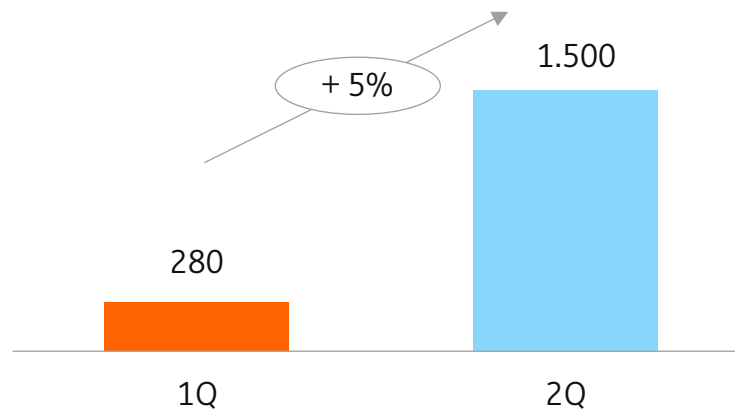
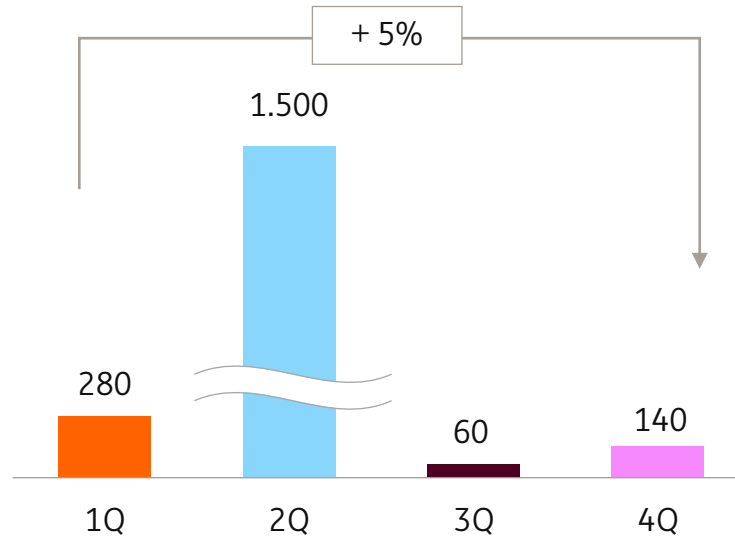

*Footnote or source 10pt ING Mid Grey

Data visualisation: Time and trends

Pick and choose your chart and scale it up to a minimum font size of 14pts

Line chart
Chart subtitle

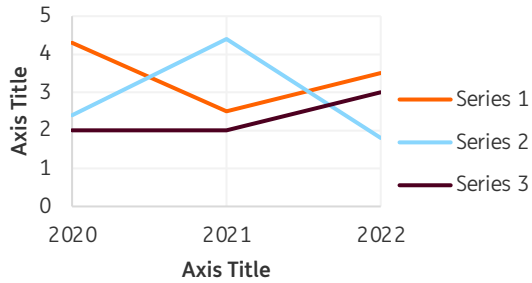

Source

Dot line chart
Chart subtitle

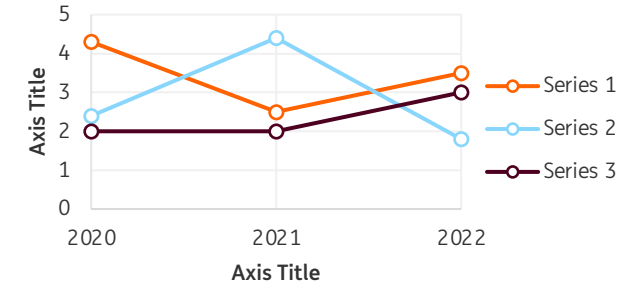

Source

Waterfall

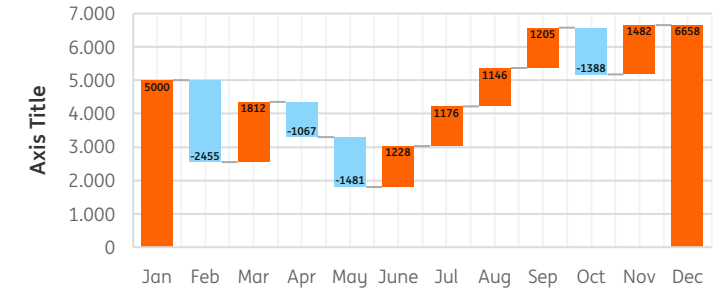

Deviation column
Chart subtitle

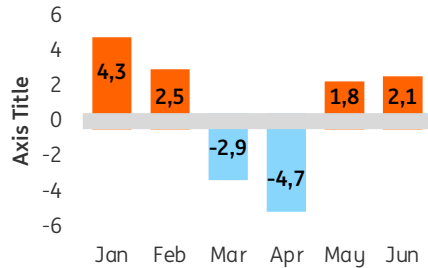

Source

Deviation line
Chart subtitle

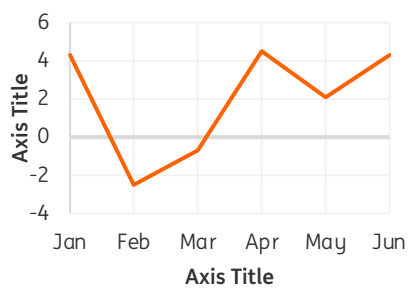

Source

Slopegraph
Chart subtitle

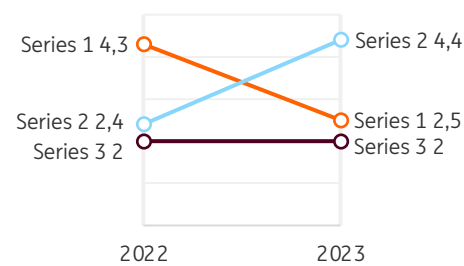

Source

Column chart
Chart subtitle

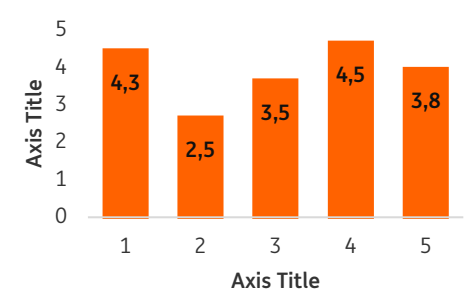

Source

Click on 'insert' > 'Chart' > 'Templates' to use ING branded charts, or copy a ready-made chart from the next slides and place your own data.

Data visualisation: Comparison of categories

Pick and choose your chart and scale it up to a minimum font size of 14pts

Bar chart

Chart subtitle

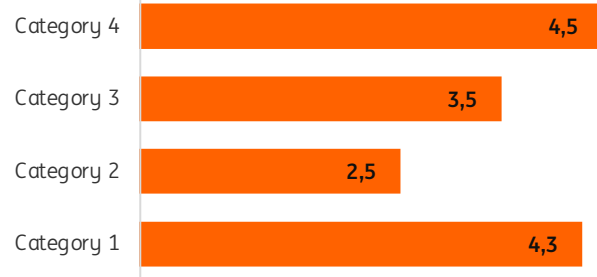

Source

Stacked bar chart

Chart subtitle

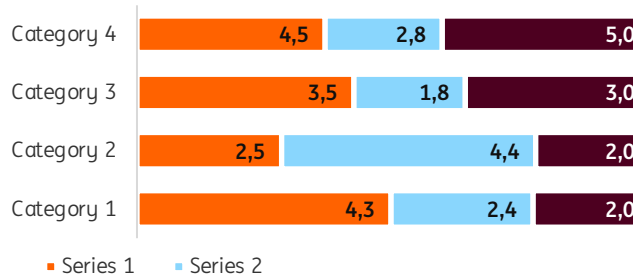

Source

Grouped bar chart

Chart subtitle

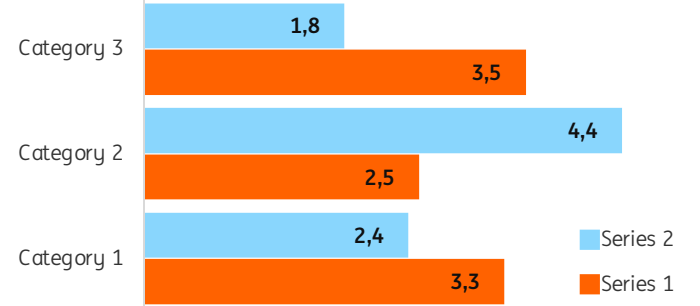

Source

Diverging bar chart

Chart subtitle

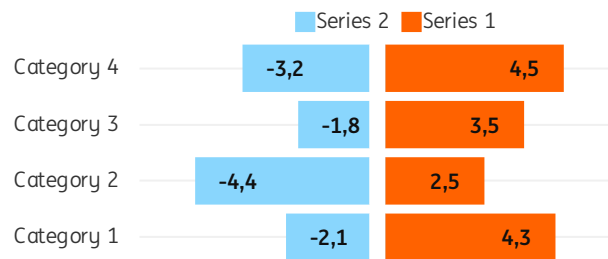

Source

Coordinate plot

Chart subtitle

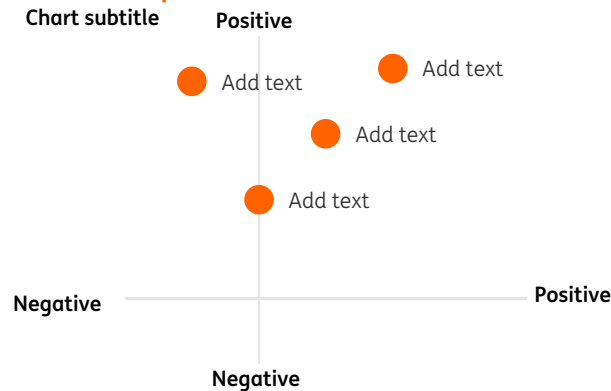

Source

Proportional area

Chart subtitle

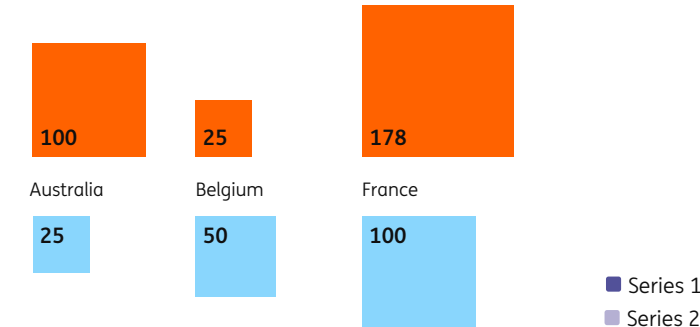

Click on 'insert' > 'Chart' > 'Templates' to use ING branded charts, or copy a ready-made chart from the next slides and place your own data.

The blob

Small
1 line and
10 characters max

[Learn more](#)

Medium
1 line and
22 characters max

[Calculate your benefit](#)

Large
1 line and
32 characters max

[Lassen Sie sich inspirieren](#)

The XL-blob
3 lines and
2 body copy
1 promotional number

Get up to
€50
Discount

The Mini-blob
Medium

2 lines and
64 characters max

[Calculate your benefit](#)

**Temporary 10% discount
in the first year.**

The Mini-blob Large

3 lines and
75 characters max

[Calculate your benefit](#)

**Temporary 10% discount
in the first year. Over
three lines of copy.**

You can find full information on how to use the blob on the [ING Brand site](#)

Legal information example

In preparing the financial information in this document, except as described otherwise, the same accounting principles are applied as in the 2015 ING Group consolidated annual accounts. All figures in this document are unaudited. Small differences are possible in the tables due to rounding.

Certain of the statements contained herein are not historical facts, including, without limitation, certain statements made of future expectations and other forward-looking statements that are based on management's current views and assumptions and involve known and unknown risks and uncertainties that could cause actual results, performance or events to differ materially from those expressed or implied in such statements.

Actual results, performance or events may differ materially from those in such statements due to, without limitation:

1. changes in general economic conditions, in particular economic conditions in ING's core markets
2. changes in performance of financial markets, including developing markets
3. consequences of a potential (partial) break-up of the euro
4. changes in the availability of, and costs associated with, sources of liquidity such as interbank funding, as well as conditions in the credit markets generally, including changes in borrower and counterparty creditworthiness
5. changes affecting interest rate levels
6. changes affecting currency exchange rates

7. changes in investor and customer behaviour
8. changes in general competitive factors
9. changes in laws and regulations
10. changes in the policies of governments and/or regulatory authorities
11. conclusions with regard to purchase accounting assumptions and methodologies
12. changes in ownership that could affect the future availability to us of net operating loss, net capital and built-in loss carry forwards
13. changes in credit ratings
14. ING's ability to achieve projected operational synergies and
15. the other risks and uncertainties detailed in the most recent annual report of ING Groep N.V. (including the Risk Factors contained therein) and ING's more recent disclosures, including press releases, which are available on www.ING.com.

Any forward-looking statements made by or on behalf of ING speak only as of the date they are made, and, ING assumes no obligation to publicly update or revise any forward-looking statements, whether as a result of new information or for any other reason.

This document does not constitute an offer to sell, or a solicitation of an offer to purchase, any securities in the United States or any other jurisdiction.